



| | | | | |
|--|--|--|-------|-----------|
|   | THERMOJET® H-2500E SERIES OIL PURIFIER SYSTEM INSTALLATION AND OPERATING MANUAL | | Doc # | 77740119 |
| | | | Rev | 15 |
| | | | Date | June 2020 |
| | Page 1 of 100 | | | |

ThermoJet® H2500E Series Oil Purifier System Installation and Operating Manual

| | | |
|--|----------------|--|
|  | WARNING |  |
| <p>READ AND UNDERSTAND THIS OPERATING MANUAL BEFORE ATTEMPTING TO INSTALL, COMMISSION, OR USE THIS EQUIPMENT. FAILURE TO UNDERSTAND THESE INSTRUCTIONS COULD RESULT IN SERIOUS PERSONAL INJURY AND OR LOSS OF PROPERTY.</p> | | |



5615 W Fuqua St B-201 • Houston, Texas 77085
1-713.464.6266 • Fax: 713.464.9871











| | | | |
|---|--|---------------|-----------|
|  | THERMOJET® H-2500E SERIES OIL PURIFIER SYSTEM INSTALLATION AND OPERATING MANUAL | Doc # | 77740119 |
| | | Rev | 15 |
| | | Date | June 2020 |
| | | Page 3 of 100 | |

Table of Contents



| | | |
|-----|---|----|
| I | GENERAL INFORMATION | 5 |
| | Manufacturer Contact Information | 6 |
| | Explanation Of Graphic Symbols In The Documentation | 7 |
| II | UNIT IDENTIFICATION AND LABELING | 10 |
| | ThermoJet ® Model H2500- Model Code Designations | 11 |
| | Model Code Designation Key | 12 |
| | Tag Detail for H2500E Model Oil Purifiers | 13 |
| III | DESCRIPTION OF THE PRODUCT | 14 |
| | Principal of Operation | 15 |
| | Dewatering | 15 |
| | Flow through the Unit | 15 |
| | The Jet Mixer | 15 |
| | Return of Clean Oil | 15 |
| | Mounting Options | 15 |
| IV | INSTALLATION | 16 |
| | Receipt Inspection | 17 |
| | Placement of Equipment | 17 |
| | Inlet and Return Oil Piping Connections | 18 |
| | Condensate Purifier Connection | 20 |
| | System Exhaust Connections | 21 |
| | Electrical Power Connection | 22 |
| | Grounding | 25 |
| V | SYSTEM START-UP AND OPERATION | 26 |
| | Start-Up Procedures | 27 |
| | Heater Operation: | 32 |
| | Adjusting System Pressure | 35 |
| | System Discharge Pressure | 36 |
| | System Vent Operation | 37 |
| | Monitoring Normal Operation | 39 |
| | Dailey ThermoJet Oil Purifier System Operational Checks | 41 |
| | System Shutdown | 42 |
| VI | ROUTINE MAINTENANCE | 43 |
| | Maintenance Checks | 44 |
| | General Inspection | 46 |
| | Oil Filter Maintenance | 47 |
| | Y-Strainer Maintenance | 48 |
| | Condensate Purifier Assembly Maintenance | 49 |
| | Oil Mist Eliminator Maintenance | 50 |
| | Air Breather Maintenance | 51 |
| | Separation Vessel Maintenance | 52 |
| | Oil Heater Maintenance | 55 |
| | Auto Tune Oil Heater Controller | 60 |
| | Check and Adjust Operating Pressures | 62 |
| | Verify Low Oil Pressure Switch Operation | 63 |
| | Verify Oil Heater High Temperature Cutout Operation | 65 |

| | | | | |
|--|--|--|-----------------------------|-----------|
|      | THERMOJET® H-2500E SERIES OIL PURIFIER SYSTEM INSTALLATION AND OPERATING MANUAL | | Doc # | 77740119 |
| | | | Rev | 15 |
| | | | Date | June 2020 |
| | | | Page 4 of 100 | |

| | |
|---|----|
| VII CLEANING AND DECONTAMINATION | 69 |
| Cleaning and Decontamination..... | 70 |
| Removal From Use, Disposal And Transport | 72 |
| Draining and Cleaning Procedures | 74 |
| VIII TROUBLE SHOOTING | 75 |
| Trouble Shooting Guide | 76 |
| Quick Reference Troubleshooting Guide..... | 79 |
| Types of Product Misapplication and Misuse Not Covered By Warranty or Guarantees..... | 80 |
| IX PARTS LIST / DRAWINGS / SCHEMATICS | 81 |
| Maintenance Spare Parts List..... | 82 |
| Process and Instrument Diagram | 83 |
| PID Symbol Legend and Customer Connection Chart | 84 |
| Electrical Wiring Diagram..... | 85 |
| Transformer Wiring | 86 |
| Fuse Ratings and Characteristics | 87 |
| Bill Of Materials | 88 |
| General Arrangement Drawings | 90 |
| Dimensional Outline Drawings..... | 94 |

| | | | | |
|--|--|--|-----------------------------|-----------|
|      | THERMOJET® H-2500E SERIES OIL PURIFIER SYSTEM INSTALLATION AND OPERATING MANUAL | | Doc # | 77740119 |
| | | | Rev | 15 |
| | | | Date | June 2020 |
| | | | Page 5 of 100 | |

I GENERAL INFORMATION

| | | | | |
|--|--|--|-------|-----------|
|   | THERMOJET® H-2500E SERIES OIL PURIFIER SYSTEM INSTALLATION AND OPERATING MANUAL | | Doc # | 77740119 |
| | | | Rev | 15 |
| | | | Date | June 2020 |
| | Page 6 of 100 | | | |

Manufacturer Contact Information

For additional information contact the manufacturing office nearest you or check our website.







For questions regarding this publication or if you have specific questions regarding the installation and operation of **ThermoJet®** Oil Purifier System, please contact









Manufacturer
 5615 W Fuqua St B-201
 Houston, Texas 77085
 USA
 Ph 1.713.464.6266
 Fx 1.713.464.7375









Explanation Of Graphic Symbols In The Documentation





The following graphic symbols are used in this publication to communicate specific detailed information necessary for the safe operation of this product. These graphic symbols are used to create “Safety Alerts” within the documentation to alert the users of potential hazards, instruction on how to avoid injury and instruction notices for safe operation. When interfacing with this product it is important these safeguards are observed.

It is important for safety alerts to have the appropriate choice of signal word because this word and its colored background communicate the severity of the hazard. The signal word calls attention to the warning and designates a degree or level of hazard seriousness. The signal words for product safety alerts as used in this manual are “DANGER”, “WARNING”, “CAUTION”, and “NOTICE”.



| SYMBOL | SYMBOL DESCRIPTION AND USE |
|---|--|
|  | This symbol is used to identify a “DANGER” level of hazard seriousness. “DANGER” indicates a hazardous situation which, if not avoided, will result in death or serious injury |
|  | This symbol is used to identify a “WARNING” level of hazard seriousness. “WARNING” indicates a hazardous situation which, if not avoided, could result in death or serious injury |
|  | This symbol is used to identify a “CAUTION” level of hazard seriousness. “CAUTION” indicates a hazardous situation which, if not avoided, could result in minor or moderate injury |
|  | This symbol is used to identify a “SAFETY ALERT” associated with either a “WARNING” or “CAUTION” severity hazard. The alert is accompanied with instruction necessary to avoid a hazard or personally injurious situation. The “SAFETY ALERT” symbol is accompanied with other graphics to further identify the type of hazard or personal injury risk involved. |
|  | This symbol is used to warn against a crushing or pinching hazard. This symbol can be used in conjunction with either a “DANGER”, or “WARNING” or “CAUTION” severity level |
|  | This symbol is used to warn against risk of creating an “EXPLOSION”. This symbol can be used in conjunction with a “SAFETY ALERT” symbol with either a “DANGER”, or “WARNING” or “CAUTION” severity level. |
|  | This symbol is used to warn against “ELECTRIC SHOCK”. This symbol can be used in conjunction with a “SAFETY ALERT” symbol with either a “DANGER”, or “WARNING” or “CAUTION” severity level. |

| SYMBOL | SYMBOL DESCRIPTION AND USE |
|---|---|
|  | This symbol is used to warn against “CRUSHING”. The equipment should never be tipped or stood on edge. This symbol can be used in conjunction with a “SAFETY ALERT” symbol with either a “DANGER”, or “WARNING” or “CAUTION” severity level. |
|  | This symbol is used to warn against “SLIP HAZARDS”. This symbol can be used in conjunction with a “SAFETY ALERT” symbol with either a “DANGER”, or “WARNING” or “CAUTION” severity level. |
|  | This symbol is used to warn against “CORROSIVE” or “CAUSTIC CHEMICALS” that might inadvertently be used to clean the equipment. Any cleaning agents used must be compatible with the equipment materials of construction and not harmful to personnel. This symbol can be used in conjunction with a “SAFETY ALERT” symbol with either a “DANGER”, or “WARNING” or “CAUTION” severity level. |
|  | This symbol is used to indicate that a “FORK TRUCK” is used to transport the equipment. The Fork truck operator should be properly trained in its operation and observe all plant driving and safety regulations. Do not transport equipment on public roadways using a fork truck. This symbol can be used in conjunction with a “SAFETY ALERT” symbol with either a “DANGER”, or “WARNING” or “CAUTION” severity level. |
|  | This symbol is used to warn against the presence of poisonous substances being present. This symbol can be used in conjunction with either a “DANGER”, or “WARNING” or “CAUTION” severity level |
|  | This symbol is used to warn against the presence of a carcinogenic substances being present. This symbol can be used in conjunction with either a “DANGER”, or “WARNING” or “CAUTION” severity level |
|  | This symbol is used to warn against the presence of a hot surfaces. This symbol can be used in conjunction with either a “DANGER”, or “WARNING” or “CAUTION” severity level |
|  | This symbol is used to warn against “SUDDEN PRESSURE RELEASE” of compressed gas. This symbol can be used in conjunction with a “SAFETY ALERT” symbol with either a “DANGER”, or “WARNING” or “CAUTION” severity level. |
|  | This symbol is used to identify “NOTICE” instructions and is used where a “SAFETY ALERT” designation is too severe. A “NOTICE” label is used for instruction or issuing a reminder about a condition which is more procedural in nature rather than related to an immediate risk of personal injury. |

| SYMBOL | SYMBOL DESCRIPTION AND USE |
|---|--|
|  | This symbol is used to indicate that gloves and other “PERSONAL PROTECTIVE EQUIPMENT (PPE)” should be used. This symbol may be used in conjunction with a “NOTICE”. |
|  | This symbol is used to indicate that eye protection and other “PERSONAL PROTECTIVE EQUIPMENT (PPE)” should be used. This symbol may be used in conjunction with a “NOTICE”. |
|  | This symbol is used to indicate that respiratory protection and other “PERSONAL PROTECTIVE EQUIPMENT (PPE)” should be used. This symbol may be used in conjunction with a “NOTICE”. |
|  | This symbol is used to indicate that lifting points are provided on equipment for safe movement and should be used. This symbol may be used in conjunction with a “NOTICE” or “CAUTION” severity level. |
|  | This symbol is used to indicate that the reader must read and understand referenced “DATA AND INFORMATION”. This symbol may be used in conjunction with a “NOTICE” or with a “SAFETY ALERT” symbol with either a “DANGER”, or “WARNING” or “CAUTION” severity level. |
|  | This symbol is used to advise “SPILLS” are to be controlled and cleaned up. In case of spillage, the user or other responsible body must ensure appropriate cleanup and decontamination is carried out. This symbol may be used in conjunction with a “NOTICE” or with a “SAFETY ALERT” symbol with either a “DANGER”, or “WARNING” or “CAUTION” severity level. |
|  | This symbol is used to encourage the use of cleaning materials which the customer can “RECYCLE”. Drained oil should be recycled. This symbol may be used in conjunction with a “NOTICE”. |
|  | This symbol is used to advise the materials must be disposed of in accordance to environmental laws ordinances and directives. Disposal methods which have “ADVERSE ENVIRONMENTAL IMPACT” are to be avoided. This symbol may be used in conjunction with a “NOTICE”. |

| | | | | |
|--|--|--|------------------------------|-----------|
|      | THERMOJET® H-2500E SERIES OIL PURIFIER SYSTEM INSTALLATION AND OPERATING MANUAL | | Doc # | 77740119 |
| | | | Rev | 15 |
| | | | Date | June 2020 |
| | | | Page 10 of 100 | |

II UNIT IDENTIFICATION AND LABELING

| | | | | |
|--|--|--|-------|-----------|
|   | THERMOJET® H-2500E SERIES OIL PURIFIER SYSTEM INSTALLATION AND OPERATING MANUAL | | Doc # | 77740119 |
| | | | Rev | 15 |
| | | | Date | June 2020 |
| | Page 11 of 100 | | | |

ThermoJet ® Model H2500- Model Code Designations

Electrical Standard:

The ThermoJet ® Model H2500E Oil Purifier is designed to comply with Class 1 Groups CD; T3C

Inlet Power:



The ThermoJet® Model H2500E Oil Purifier is available for connection to the following electrical power supplies. The purchaser specifies supply voltage

- 460 VAC / 60 Hz / 3 Phase
- 575 VAC / 60 Hz / 3 Phase
- 380 VAC / 50 Hz / 3 Phase
- 400 VAC / 50 Hz / 3 Phase
- 415 VAC / 50 Hz / 3 Phase
- 440 VAC / 50 Hz / 3 Phase

Mounting:

The ThermoJet® Model H2500E Oil Purifier is available with the following mounting methods. The purchaser specifies mounting method.

- Base Mounted with feet and lifting eyes (standard)
- Portable base with casters and towing handle
- Trailer mounted, single axle
- Fork-lift able

| | | |
|---|--|---|
|  |  <p>EXPLOSION HAZARD – Substitution of components may impair suitability for Class 1 Groups CD; T3C</p> |  |
|---|--|---|

Model Code Designation Key

ThermoJet ® Model H2500E
Oil Purifier



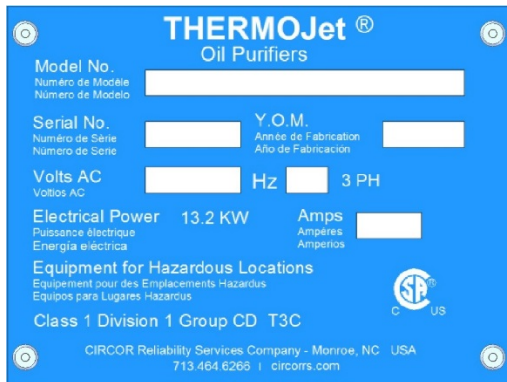

| Option Description | Option Code | Description |
|---|-------------|---|
| Application Type Electrical Area Classification | H2500 | Dewatering Application in Hydrocarbon Processing Industry Unit for Class 1 Grps CD T3C 22" X 30" footprint |
| Heater Type | E | Electric Heater |
| Electrical Power Supply | A | 460 VAC, 60 Hz, 3 Phase |
| | D | 575 VAC / 60 Hz / 3 Phase |
| | E | 380 VAC, 50 Hz, 3 Phase |
| | C | 400 VAC, 50 Hz, 3 Phase |
| | K | 415 VAC, 50 Hz, 3 Phase |
| | M | 440 VAC, 50 Hz, 3 Phase |
| Mounting | BL | Base Mounted with feet and lifting eyes |
| | PB | Portable base with casters and towing handle |
| | TR | Trailer mounted, single axle |
| | FL | Fork-lift able |
| Export Crating (excluding North America, South America & Canada) | | Export Crating |

| | | | | |
|---|--|--|------------------------------|-----------|
|  | THERMOJET® H-2500E SERIES OIL PURIFIER SYSTEM INSTALLATION AND OPERATING MANUAL | | Doc # | 77740119 |
| | | | Rev | 15 |
| | | | Date | June 2020 |
| | | | Page 13 of 100 | |

Tag Detail for H2500E Model Oil Purifiers



| Data Ref. | Description | Example |
|------------|---|--|
| Model No. | Per Customer. P.O. & Manufacture Job Order See " ThermoJet ® Oil Purifier Model Code Designation Key" _____ | H2500-**** |
| Serial No. | fluid | X . . . X |
| Volts AC | Machinery is available for connection to either 380 VAC, 415 VAC or 460 VAC electrical power. Purchaser specifies the electrical power requirement. Reference " ThermoJet ® Oil Purifier Model Code Designation Key" Power Option Code A 460 VAC 60 Hz _____ Power Option Code D 575 VAC 60 Hz _____ Power Option Code E 380 VAC 50 Hz _____ Power Option Code C 400 VAC 50 Hz _____ Power Option Code K 415 VAC 50 Hz _____ Power Option Code M 440 VAC 50 Hz _____ | 460 VAC 575 VAC 380 VAC 400 VAC 415 VAC 440 VAC |
| HZ | Machinery is suitable for 50 or 60 hertz AC power as stipulated by the "POWER" option of the "ThermoJet ® Oil Purifier Model Code Designation Key" Power Option Code A 460 VAC 60 Hz _____ Power Option Code D 575 VAC 60 Hz _____ Power Option Code E 380 VAC 50 Hz _____ Power Option Code C 400 VAC 50 Hz _____ Power Option Code K 415 VAC 50 Hz _____ Power Option Code M 440 VAC 50 Hz _____ | 60 Hz 60 Hz 50 Hz 50 Hz 50 Hz 50 Hz |
| Power | Maximum operating power requirement at the specified voltage with the power selector switch in the "ON" position with the electric motor running and the oil heater fully energized. Reference " ThermoJet ® Oil Purifier Model Code Designation Key" Power Option Code A 460 VAC 60 Hz _____ Power Option Code D 575 VAC 60 Hz _____ Power Option Code E 380 VAC 50 Hz _____ Power Option Code C 400 VAC 50 Hz _____ Power Option Code K 415 VAC 50 Hz _____ Power Option Code M 440 VAC 50 Hz _____ | 13.5 KW / 18 Amps 13.5 KW / 14 Amps 13.5 KW / 21 Amps 13.5 KW / 20 Amps 13.5 KW / 20 Amps 13.5 KW / 19 Amps |
| YOM | Year Of Manufacture | YYYY |

| | | | | |
|--|--|--|------------------------------|-----------|
|      | THERMOJET® H-2500E SERIES OIL PURIFIER SYSTEM INSTALLATION AND OPERATING MANUAL | | Doc # | 77740119 |
| | | | Rev | 15 |
| | | | Date | June 2020 |
| | | | Page 14 of 100 | |

III DESCRIPTION OF THE PRODUCT

| | | | | |
|---|--|--|------------------------------|-----------|
|  | THERMOJET® H-2500E SERIES OIL PURIFIER SYSTEM INSTALLATION AND OPERATING MANUAL | | Doc # | 77740119 |
| | | | Rev | 15 |
| | | | Date | June 2020 |
| | | | Page 15 of 100 | |

Principal of Operation

The ThermoJet Oil Purifier works on the principal of air stripping. The use of air bubbled through contaminated liquids has long been used to remove contaminants. But the use of this technique was restricted because the volume of gas required was large due to limited mixing of the gas with the liquid. The unique technology embodied by the ThermoJet makes air stripping practical and efficient because of the mixing and intimate contact of the air with the fluid being cleaned. In addition, the ThermoJet utilizes the principal that the capacity of air to entrain moisture increases exponentially with temperature.

The ThermoJet is designed to operate on ISO 32 through ISO 220 oils from circulating oil systems. Oil with higher viscosity (ISO 150 and ISO 220) must be at 40° C (100°F) minimum temperature at the inlet to the ThermoJet during start-up.

Dewatering

The ThermoJet® removes dissolved and emulsified water from industrial lubricants. The ThermoJet returns the viscosity of the lube oil and restore it to like new levels. No longer is there a need to dispose of water laden lube oils; these oils can be purified and reused.

Flow through the Unit

The suction pump of the ThermoJet draws contaminated oil from the user lube or hydraulic system. Flexible hose or hard piping can be used to connect the ThermoJet to the system reservoir. A one and one half horsepower motor drives the suction pump. The suction pump is protected by a “Y” strainer. From the pump the oil passes through a filter. This cartridge filter can be easily replaced. It is recommended replacement be made when the pressure differential across it, as monitored by two easily read gages which are externally mounted on the panel above the access door, reaches 30 PSI (2 BAR). From the filter the oil passes through the heater that elevates the oil to 180° F (82° C). The electric heater temperature is set and controlled with a solid-state temperature controller whose operation is viewed through a window on the electrical control box. After the heater, the oil passes through the heart of the ThermoJet, the dual stage jet mixer

The Jet Mixer

This proprietary and uniquely designed device is the heart of the system. Without the aid of secondary pressure, it continuously and automatically draws ambient air into the heated oil stream as delivered to it by the inlet pump. The ambient air becomes intimately mixed with the oil and assumes the temperature of the oil and absorbs water from the oil. The oil leaves the Jet Mixer and is directed to the separation vessel that operates at atmospheric pressure. Here the moisture laden air expands and leaves the oil thus cleansing the oil of water.





Return of Clean Oil

In the separation vessel the oil from the jet mixer cascades down trays to promote the release of the water laden air. A volume of oil is maintained in the lower portion of the separation vessel to allow any entrained air to leave the oil so that none is contained in the return oil stream. The second close coupled pump driven by the electric motor returns oil to the user reservoir. Water vapor vents from the separation vessel and travels through a filter and oil absorbing media to insure that discharge from the unit is oil free. The water condensate discharged from the ThermoJet can be piped to a sanitary sewer.

Mounting Options

The ThermoJet Model H2500 Oil Purifier is offered in two different mounting configurations so that the unit can best fit client requirements. All series units are available as base mounted with lifting eyes. See the H2500E Model Code sheet for additional mounting options.

IV INSTALLATION

| | | |
|---|---|---|
|  | <p>WARNING</p> <p>If the equipment is not used in the manner described in this manual the protection provided by the equipment may be impaired</p> |     |
|---|---|---|

| | | |
|---|--|---|
|  | <p>WARNING</p> <p>THIS INSTRUMENT MUST BE EARTHED</p> |  |
|---|--|---|

| | | | | |
|---|--|--|----------------|-----------|
|  | THERMOJET® H-2500E SERIES OIL PURIFIER SYSTEM INSTALLATION AND OPERATING MANUAL | | Doc # | 77740119 |
| | | | Rev | 15 |
| | | | Date | June 2020 |
| | | | Page 17 of 100 | |

Receipt Inspection

Remove all shipping materials and plastic plugs.

Inspect for shipping damage externally and internally (open enclosure door), and immediately report any damage found to the delivering freight company. It is desirable to take photographs of any damage to substantiate your claim.



Inspect for completeness of materials and equipment against the packing list and the purchase order. If you believe there are discrepancies, notify customer service.

Placement of Equipment

Locate the ThermoJet® Oil Purifier as close as possible to the oil reservoir in an upright position. For base mounted units verify the adequacy and strength of all relevant supporting surfaces, See Dimensional Drawings in the PARTS LIST / DRAWINGS / SCHEMATICS section of this manual for anchor bolt and equipment clearance dimensions

| | |
|---|---|
|  | <p>NOTICE: Be sure to leave working space around the system and consider space requirements for electric heater removal, fully opened access door, control panel enclosure door, and gauge monitoring.</p> |
|---|---|

The base mounted ThermoJet Oil Purifier is constructed with lift rings to assist in equipment placement. Ensure that lifting equipment and rigging is suitable for safely lifting, moving and placing the equipment.

| | | |
|---|--|--|
|  |  |   |
| <p>Use suitable transport equipment for lifting and setting the equipment into place. Ensure that the equipment is secured prior to and during lifting and transport. Stand clear of the all equipment while being maneuvered. Crane and fork truck operators should be properly trained in there operation.</p> | | |

| | | |
|---|--|---|
|  |  |  |
| <p>Do not tip or stand equipment on edge</p> | | |

Using standard plant practices secure the ThermoJet Oil Purifier to the installation surface by bolting the four (4) mounting feet.

Inlet and Return Oil Piping Connections

The oil inlet and outlet connection sizes are 1" FNPT. The user suction and discharge line sizes (either schedule 40 (min) pipe or smooth I.D. hose) should be ¾" I.D. minimum and 2" I.D. maximum to ensure that no flow restrictions will occur due to line lengths, high viscosity, etc. When processing high viscosity oils, the larger sizes of pipe or hose should be used. If tubing is used, increase the diameter by at least one size. All connections should be tight and free of air leaks.

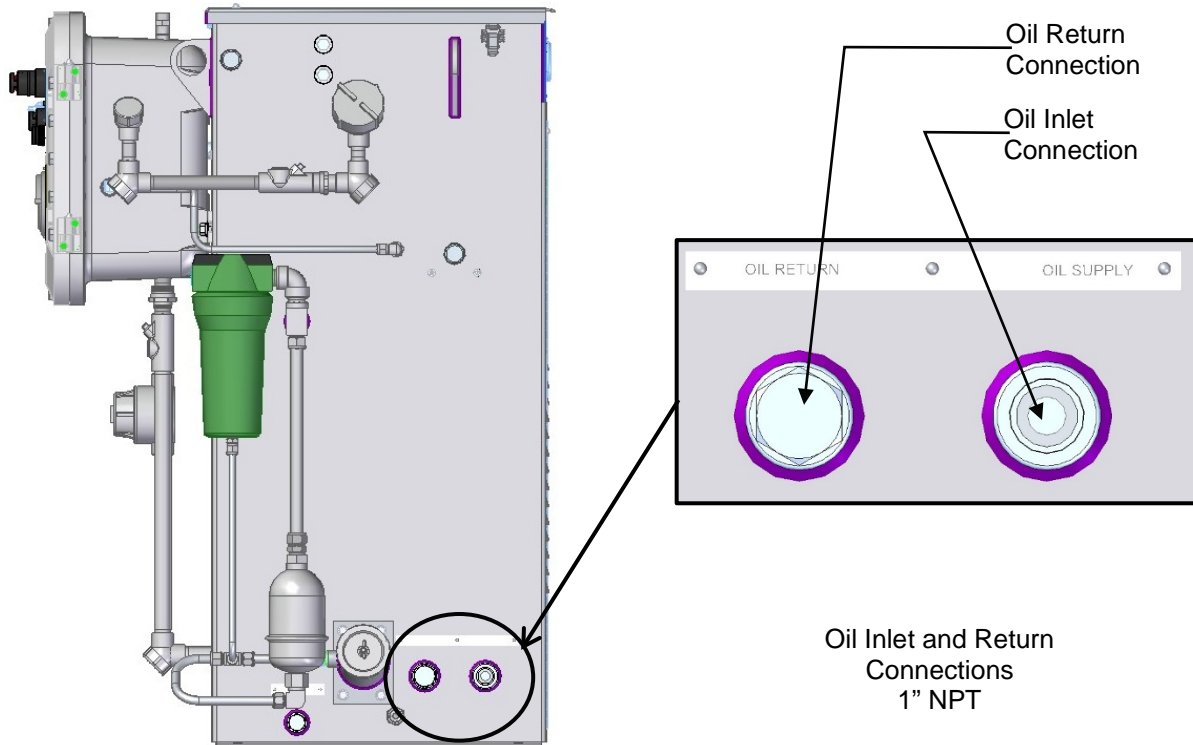

NOTICE:

Even very small air leaks can dramatically affect pump suction performance.

If a flooded suction to the ThermoJet Oil Purifier is not practical, ensure that the suction height from the reservoir drain to the inlet connection of the ThermoJet® is no more than 8 feet (2.4 meters) above the minimum oil level in the reservoir.

If the suction lift exceeds 8 feet (2.4 meters), install a foot-valve or foot-pump to ensure that the suction pump will prime and hold prime during long-term service.

Ensure that the oil return connection is above the oil level in the reservoir to prevent back flow and flooding of the separation tank when the ThermoJet® is not operating. Return oil must be introduced into the reservoir above the oil level to prevent siphoning when the ThermoJet® is not operating.

| | | | |
|---|--|------------------------------|-----------|
|  | THERMOJET® H-2500E SERIES OIL PURIFIER SYSTEM INSTALLATION AND OPERATING MANUAL | Doc # | 77740119 |
| | | Rev | 15 |
| | | Date | June 2020 |
| | | Page 19 of 100 | |

To prevent the potential risk of static electricity ensure that free falling oil does not exceed 6 inches (150 mm). If the oil return level exceeds 6 inches (150 mm), insert a guide baffle to smooth out flow to the oil surface in the reservoir.

Even if the ThermoJet® is to be installed temporarily, it should be hard-piped for safety reasons. Hoses are acceptable if they are certified not to collapse under vacuum conditions and are rated for 600 PSIG (42 bar) at 200° F (100° C).

Since all wetted parts of the ThermoJet® are constructed of type 300 stainless steel, it is recommended (but not mandatory) that connecting hard pipe work is also stainless steel. In accordance with good piping practice, the use of joints, bends, and unnecessary long pipe runs should be minimized. Elevated sections of suction piping in horizontal runs also must be avoided to prevent air pockets from existing.

Connect the suction line to the reservoir low point drain, or to existing purifier connections if the reservoir is constructed in accordance with API 614.

| | |
|---|--|
|  | <p>NOTICE: Ensure that the supply connection to the ThermoJet Oil Purifier is not adjacent to or near any oil return connection in the oil reservoir being serviced. This could result in oil frothing.</p> |
|---|--|

When a flooded suction is provided to the ThermoJet Oil Purifier, recommended practice is to install a manual shut-off valve (if one does not already exist) directly onto the reservoir connection routed to the ThermoJet® inlet connection.

If the oil reservoir is located below the ThermoJet® oil inlet connection, a manual shut-off valve is not required or desirable since it creates a line restriction unnecessarily.

The discharge line should be connected above the oil surface and at the opposite end of the reservoir versus the suction connection to ensure optimum circulation of oil through the ThermoJet®. An oil purifier return connection will exist if the reservoir is constructed in accordance with API 614.

| | |
|---|--|
|  | <p>NOTICE: Do not install any valves or other restrictive devices in the discharge line which could cause back flow and flooding of the unit.</p> |
|---|--|

Choose a central convenient location, allowing enough room to connect oil supply and return piping and electrical services. Ensure that unrestricted operator access is maintained at the front of the unit when the cabinet door is open for system operation and ease of access to the electrical control enclosure.

The ThermoJet Oil Purifier has maintenance access doors on the front of the cabinet. Ensure that unrestricted access is provided for system troubleshooting and maintenance.

Condensate Purifier Connection

Condensate Purifier Assembly (CPA) connection is ½" FNPT. Pipe CPA connection is to a dirty / oily water drain system.

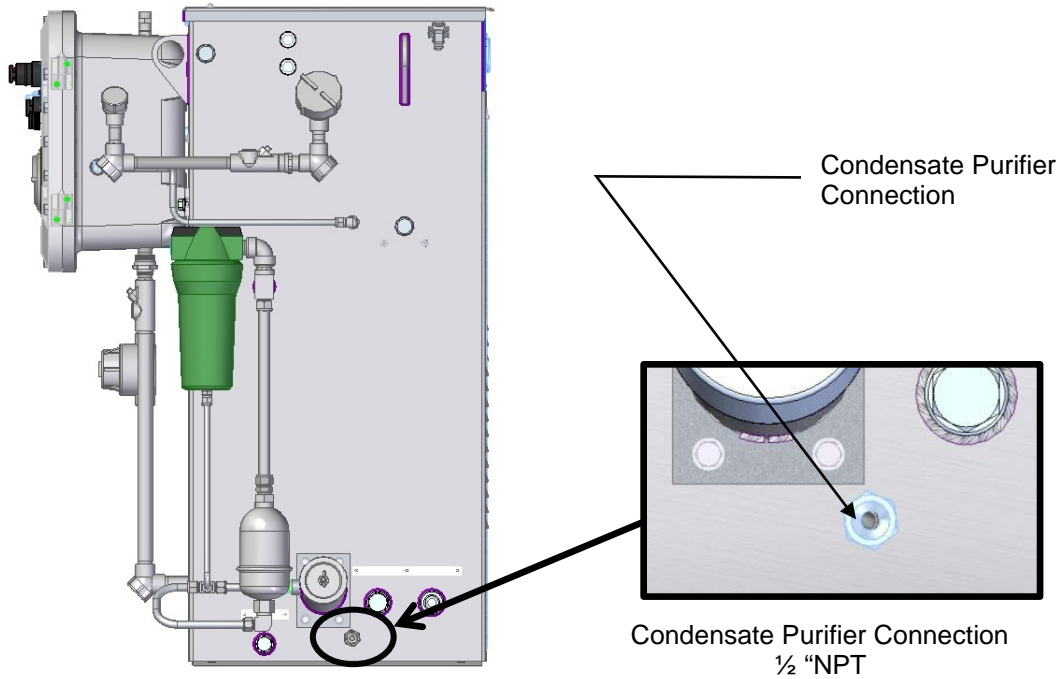

NOTICE:

When cleaning oil spills consult with your lubricating oil supplier and the lubricating oil MSDS documentation regarding safe guards and Personal Protective Equipment (PPE) requirements



System Exhaust Connections

The exhaust connection is at the 3/4" FNPT demisting filter outlet". Do not reduce the connection size. Smaller connection size will reduce the flow of air supply through the jet mixer.

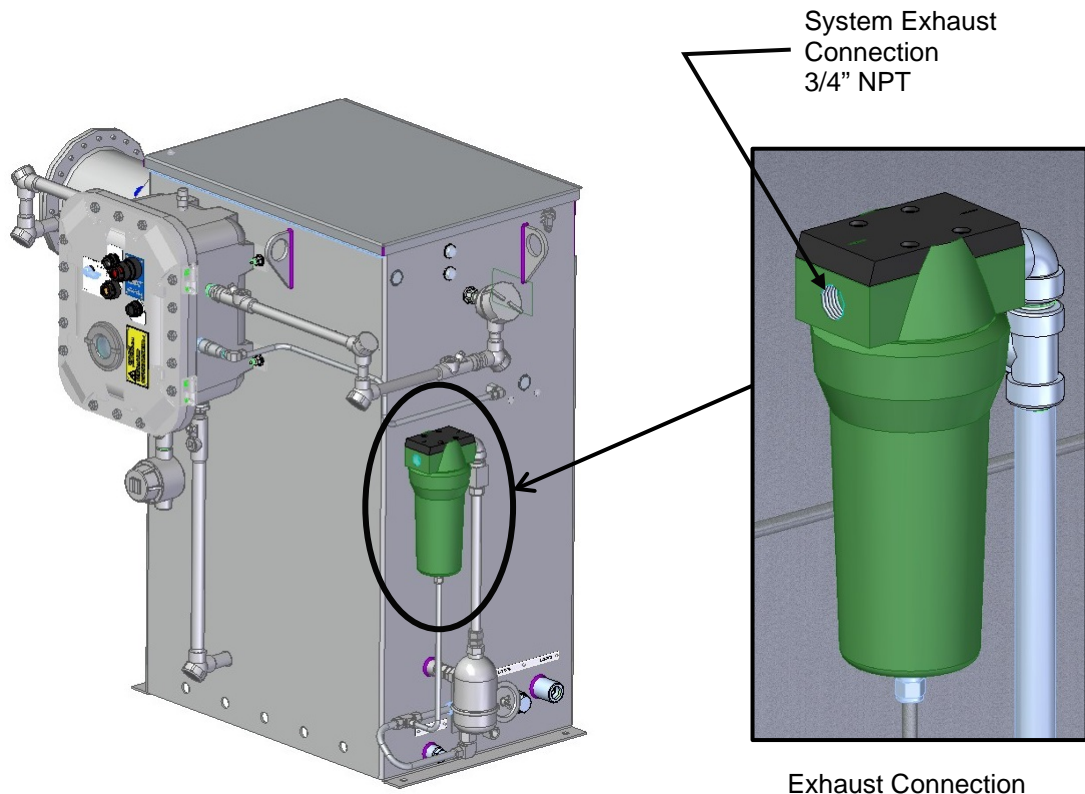

| | | |
|--|---|--|
| | <h1>CAUTION</h1> | |
| | <p>This machine is designed to remove water contamination from the processed oil.</p> | |
| | <p>Discharge connection must be made only to a safe space away from walkways and occupied spaces.</p> | |
| | <p>DO NOT BREATH DISCHARGE VAPORS</p> | |

The exhaust must be piped away to a location that is not occupied. The ends of the vent header pipe should be such that rain, animals and blowing dust and dirt cannot enter. Exhaust piping must be 3/4" NPT (DN20) or larger. Exhaust piping must extend vertically at least 15 feet / 4.5 m above the ThermoJet Oil Purifier.

Electrical Power Connection

Supply power service is made at a terminal enclosure below the controller. The connection is 3/4" conduit

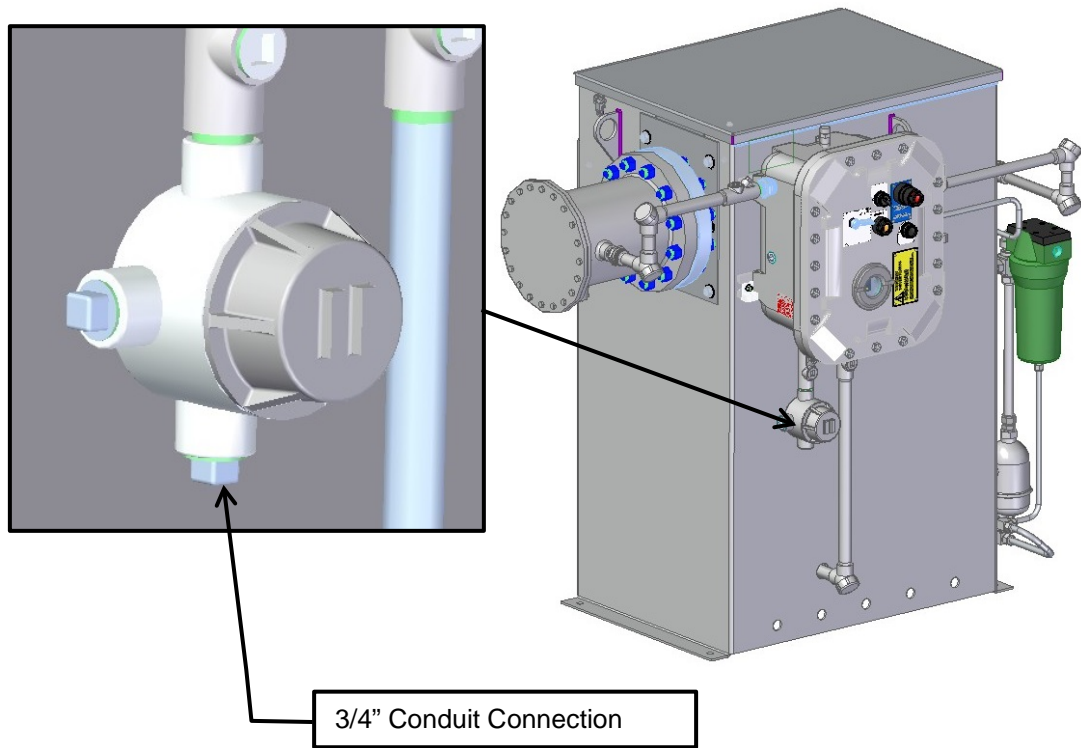

There are no ventilation requirements as long as the unit meets the operating conditions.

| | | | |
|---|--|--|--|
| | <div style="background-color: red; color: white; padding: 5px; border-radius: 15px; display: inline-block;">WARNING</div> | | |
| <p>EXPLOSION HAZARD – Do not connect equipment unless supply power has been switched OFF and the area is known to be non-hazardous / safe.</p> | | | |

ThermoJet Oil Purifier is wired for the power supply stated on the nameplate. It must not be re-wired for any other voltage. The power circuit requirements are indicated in the table below. The table shows amperage rating with pump motors running and oil heaters "ON".



WARNING



Electrical power service must have adequate circuit protection. Use the table below for selection of proper user provided interrupt device.

| Model | Volts AC | Hertz | Phase | Amperes |
|------------|----------|-------|-------|---------|
| H2500 EA** | 460 | 60 | 3 | 18 |
| H2500 ED** | 575 | 60 | 3 | 14 |
| H2500 EE** | 380 | 50 | 3 | 21 |
| H2500 EC** | 400 | 50 | 3 | 20 |
| H2500 EK** | 415 | 50 | 3 | 20 |
| H2500 EM** | 440 | 50 | 3 | 19 |

ThermoJet H2500E Oil Purifier Power Requirements



NOTICE:
All electrical connections should only be made by a qualified electrician.



WARNING



A switch or circuit breaker shall be included in the building installation; it shall be in close proximity to the equipment and within easy reach of the OPERATOR; it shall be marked as the disconnecting device for the equipment.

Access the power terminals by unscrewing the cover on the terminal enclosure. Service power to the ThermoJet Oil Purifier originates at terminals L1,-L2 and L3 located in a terminal enclosure. See the diagrams below for terminal location and user terminal connection identification. The power connection is three phase. Voltage is as specified on the equipment nameplate. Once all cable connections are securely connected, reinstall the enclosure cover.

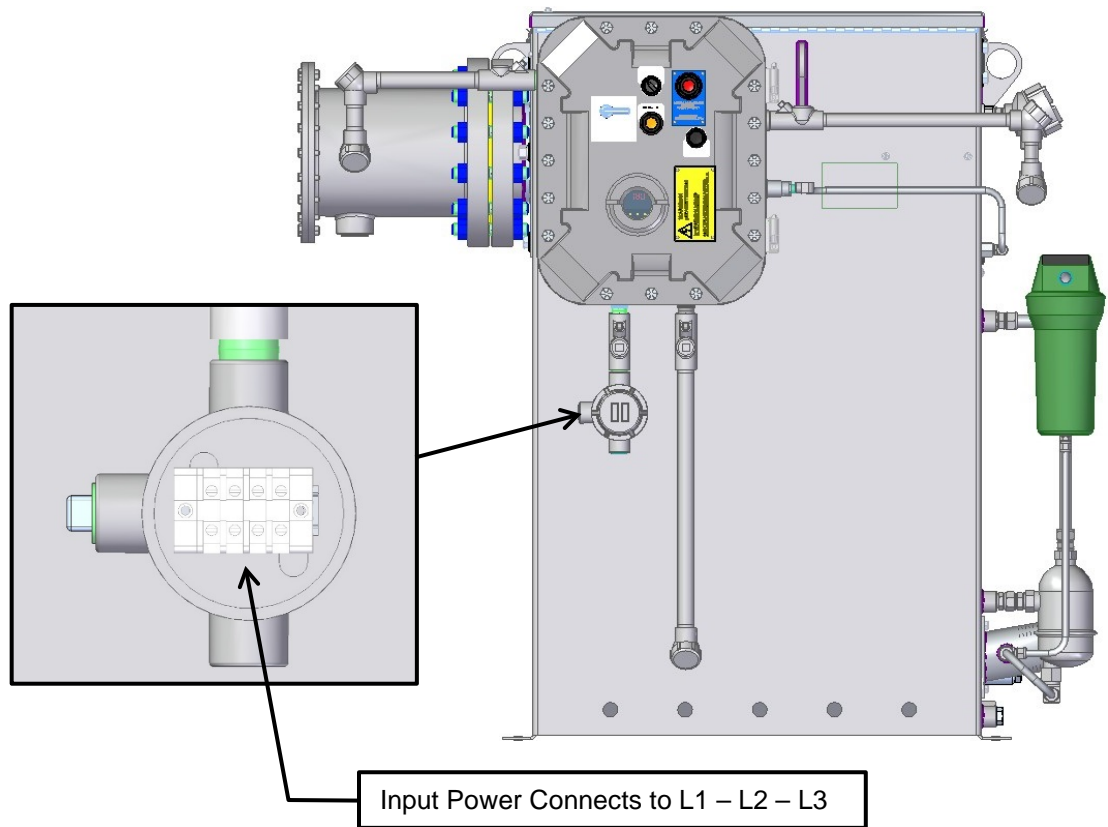

WARNING

To avoid risk of explosion hazard, the Terminal Enclosure cover must be securely closed with the threaded cover.





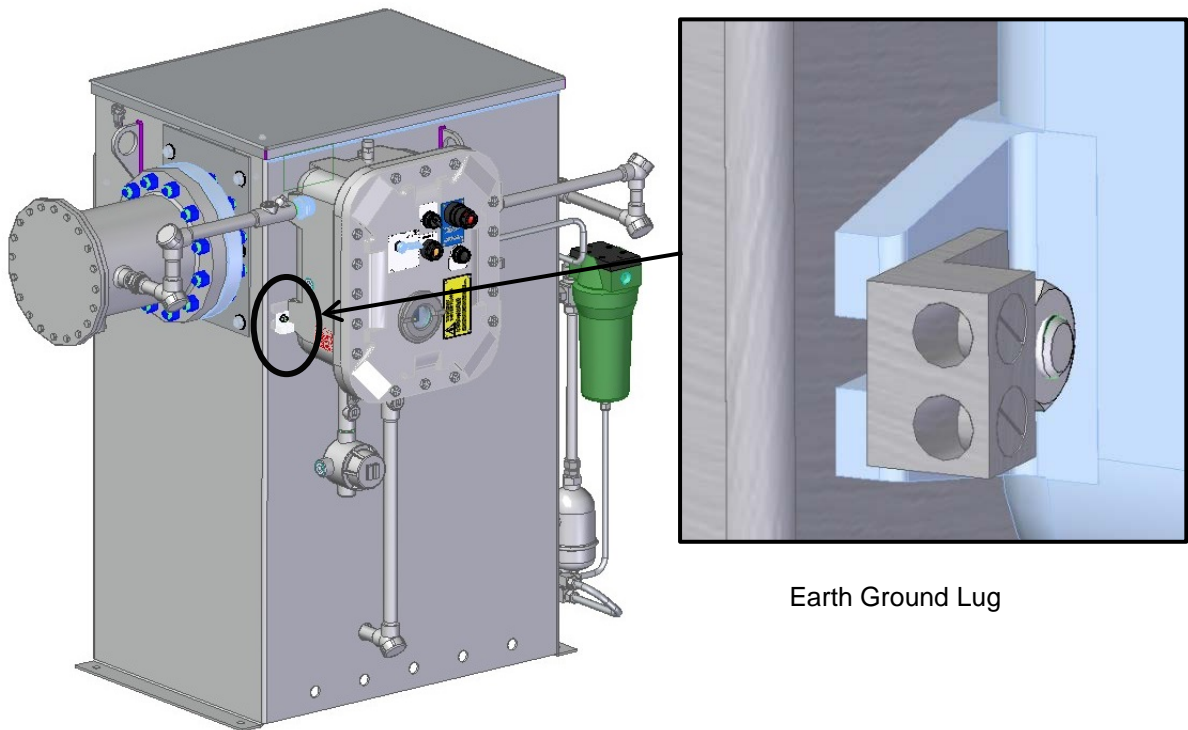

Grounding

ThermoJet Oil Purifiers must be grounded to ensure safe operation. An external ground terminal is located on the left side of the terminal enclosure. See diagrams below for circuit ground connection location. Suitable wire size range is 1/0 - #14 STR.



Earth Ground Lug

| | | | | |
|--|--|--|------------------------------|-----------|
|      | THERMOJET® H-2500E SERIES OIL PURIFIER SYSTEM INSTALLATION AND OPERATING MANUAL | | Doc # | 77740119 |
| | | | Rev | 15 |
| | | | Date | June 2020 |
| | | | Page 26 of 100 | |

V SYSTEM START-UP AND OPERATION



Start-Up Procedures



Before each start-up, perform a “walk-around” of the purifier installation noting if the points covered in INSTALLATION Section of this manual are correct.



Ensure that the oil filter element is installed in the filter housing and that the O-ring is in good condition.

Open the oil supply block valve at the serviced oil reservoir.

Use the block valve on the bottom of the reservoir to drain any free water which may have accumulated. Care should be taken to avoid spills and ground contamination with the drained waste.

| | | |
|--|----------------|---|
|  | CAUTION |  |
| <p>Avoid inputting free water from the serviced reservoir from being input into the ThermoJet Oil Purifier. Free water will flash to steam when introduced into the heater, creating sudden surges in system pressure.</p> | | |
| <p>DRAIN ALL FREE WATER FROM THE SEVICED RESERVOIR</p> | | |

| | | |
|---|---|--|
|  | <p>NOTICE: When cleaning oil spills consult with your lubricating oil supplier and the lubricating oil MSDS documentation regarding safe guards and Personal Protective Equipment (PPE) requirements</p> |   |
|---|---|--|

| | | |
|--|----------------|---|
|  | CAUTION |  |
| <p>In case of oil spillage, the user or other responsible body must ensure appropriate cleanup and decontamination is carried out.</p> | | |
|  | | |



NOTICE:
Recycle all drained oils.



NOTICE:
Dispose of all contaminated cleaning materials in accordance with all environmental laws, ordinances and directives. Consult your company or plant environmental protection department for disposal policy. Understand the environmental effect of any used cleaning agents used and plan your cleanup accordingly.



Use environmentally friendly products and recycle where ever possible



Ensure that the ThermoJet Oil Purifier Main Disconnect switch and the ON-OFF Selector Switch both are in the OFF position.

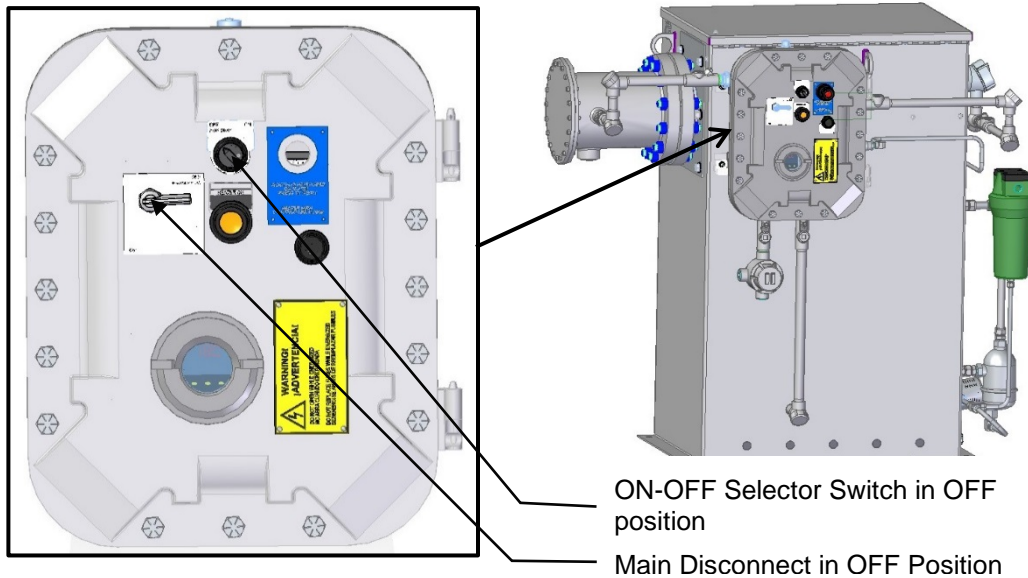

Turn "ON" electrical power at the energy source breaker.

Turn the Main Disconnect handle to the ON position. Use the ON-OFF Selector switch to jog the electric motor and check proper motor rotation. Verify the motor rotation against the directional arrow located on drive end of the motor.

If incorrect, place the Circuit breaker in the OFF position and disconnect supply power at the source.





Ensure that all sources of electrical power are disconnected before opening the controller. Failure to do so may result in serious injury or even death.



Open the Controller Enclosure and interchange any two of the three incoming power supply leads at the circuit breaker. Ensure all cable terminations are secure before closing and securing the enclosure door with all bolts.





To avoid risk of explosion hazard, the Controller Enclosure cover must be securely closed with the supplied fasteners.



Turn the Main Disconnect handle to the ON position, and again use the ON-OFF Selector Switch to jog the electric motor and verify proper motor rotation. Once the motor rotation is correct leave the Selector Switch in the ON position and allow the motor to run.

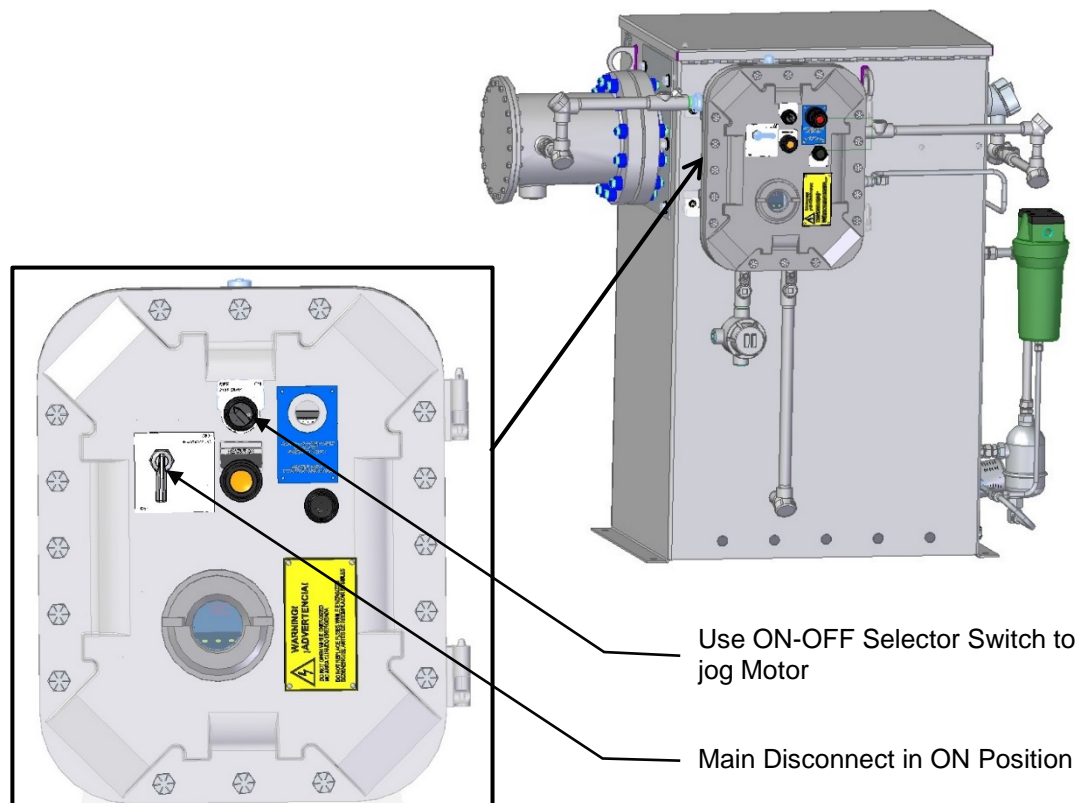

Use the air bleed/sample valve on the downstream of the inlet pump so that air in the suction line can escape. As soon as oil flow is established, close this valve to prevent any oil spills.

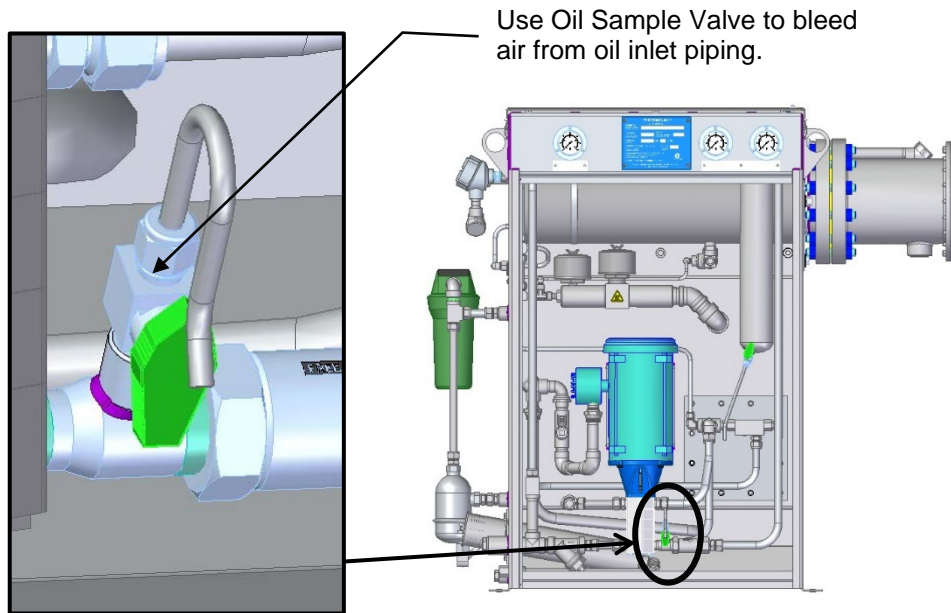



WARNING



Pump outlet pressure may build quickly. Open valve slowly. Use a container to catch and collect any oil that drains from sample tube





CAUTION

In case of oil spillage, the user or other responsible body must ensure appropriate cleanup and decontamination is carried out.



NOTICE:

Wear appropriate personal protective gear.

When cleaning oil spills consult with your lubricating oil supplier and the lubricating oil MSDS documentation regarding safe guards and Personal Protective Equipment (PPE) requirements



Wait a maximum of 2 minutes for the oil pump to establish oil flow and pressurize the inlet system. As oil flows into the pump, system pressure will build and be indicated on the filter inlet and filter discharge pressure gauges located above door. If pressure does not build and no oil is flowing, trace the inlet piping for blockages such as a closed valve. If the oil path is free from obstructions, manually prime the pump and the inlet piping. Ensure that the suction line distance is within the allowable limit as mentioned in INSTALLATION Section of this manual



Observe pressure gauges to verify that oil is flowing into the ThermoJet Oil Purifier.

Heater Operation:

The electric heater will not energize until flow is established and all the air escapes from the heater tube and the oil pressure builds. This ensures that the heater does not energize before it is immersed in oil. A pressure switch connected to the oil supply tubing downstream of the heater. The pressure switch provides a permissive start interlock and allows the heater to energize once the oil pressure reaches 135 PSI (9.3 BAR). This may be noted on the inlet pump discharge and filter discharge pressure gauges as well as by the amber HEATER ON indicator light.



Oil heater

Pump and filter discharge pressure gauges indicates system pressure

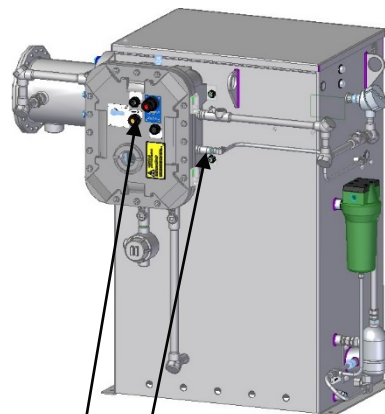

Pressure switch provides permissive interlock with the oil heater

Amber HEATER ON pilot light illuminates when heater is energized

At initial start-up the red Heater High Temperature alarm pilot light and the yellow Heater ON will be illuminated. Press the Heater High Temperature Alarm reset button to reset the high temperature alarm and turn the Heater High Temperature alarm pilot light OFF. The yellow Heater On pilot light will remain ON until the oil temperature approaches the normal operating temperature set by the temperature controller.

The temperature controller is factory set at 180° F (82° C) and is field adjustable. The temperature controller is accessed by unscrewing the glass window from the explosion proof electrical enclosure.



CAUTION

Care should be taken when removing and reinstalling the glass window into the controller enclosure so as to prevent damage to any flame proof joint between the enclosure and the treaded cover. Flameproof joints are not to be repaired in the field. If the flame path is damaged the enclosure is to be removed from service and replaced with a new properly working enclosure.

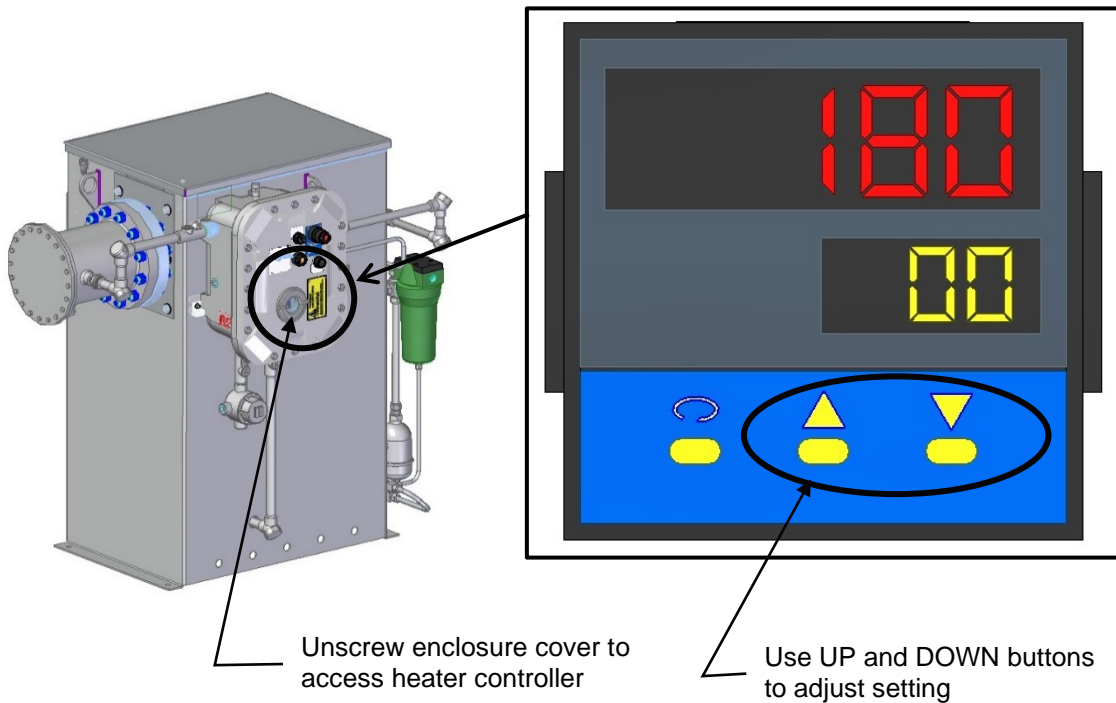

When making adjustments to the oil heater control temperature setting the system must be energized and operating. Before removing the cover to the controller contact appropriate operating personnel and obtain all required hot work permits. Ensure that the area has been inspected and determined to be nonhazardous. Observe all hot work permit procedures and policies.

Press the up or down arrow keys quickly on digital display. This will brighten the individual digit of the display. Once the desired digit is brighten, simply hold down the up or down key to increase or decrease the value. Perform this procedure with each digit until desired temperature setting is reached. Temperature is now set. The alarm modes in the controller are not being used.

The oil heater is equipped with two (2) thermocouples for monitoring heater operation.

- A thermocouple is in the oil stream located at the heater vessel discharge. This thermocouple provides the oil temperature signal to the temperature controller (see above) for heater ON-OFF control
- A thermocouple is clamped to the outside of the heater vessel. This thermocouple provides a signal for a high temperature alarm and cutout for the heater vessel surface.

Should the vessel surface thermocouple output reach the high temperature alarm/heater cutout setting, power to the oil heater element is interrupted. When this happens the oil temperature as indicated on the heater controller display will begin to decrease. As the oil temperature falls below oil heater controller setting, the heater controller will sense the decreasing oil temperature and attempt to energize the heater. However the high limit controller will prohibit the oil heater from energizing and oil temperature will continue to fall. The Heater On pilot light will be illuminated because the heater controller is providing an ON signal to the heater power control relay.

| | |
|---|---|
|  | <p>NOTICE: When a Heater High Temperature alarm occurs the red press-to-test pilot light will illuminate. The alarm pilot light will remain illuminated and the oil heater will not be operable until the press-to-test Heater High Temperature reset button is depressed. Press to resume heater operation.</p> |
|---|---|

Adjusting System Pressure

The pressure control valve (**PCV1**) downstream of the Oil Heater is factory set at 16.5 BAR (240 PSIG) at the heater process temperature of 82° C (180° F). Initially, the filter inlet and outlet pressures will vary due to higher oil viscosity at start-up.

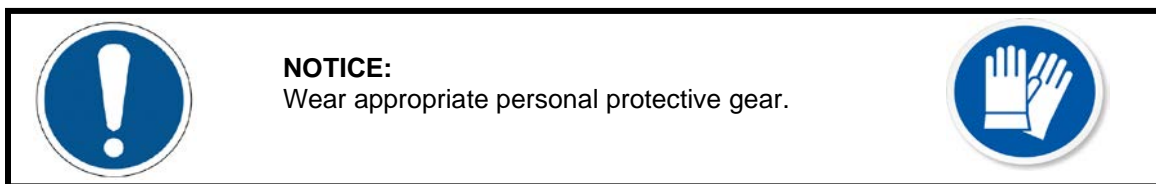

Once the oil temperature approaches the normal operating range, the pressure will return to the normal operating setting of approximately 240 PSIG (16.5 BAR). Slight adjustment to the operating pressure may be necessary. If the pump discharge pressure is too low, adjust PCV1 by turning adjustment screw clockwise to increase the oil pressure and c-clockwise to decrease the oil pressure setting. Once adjusted, the filter discharge pressure range should be 210-240 PSIG (14.5-16.5 BAR).

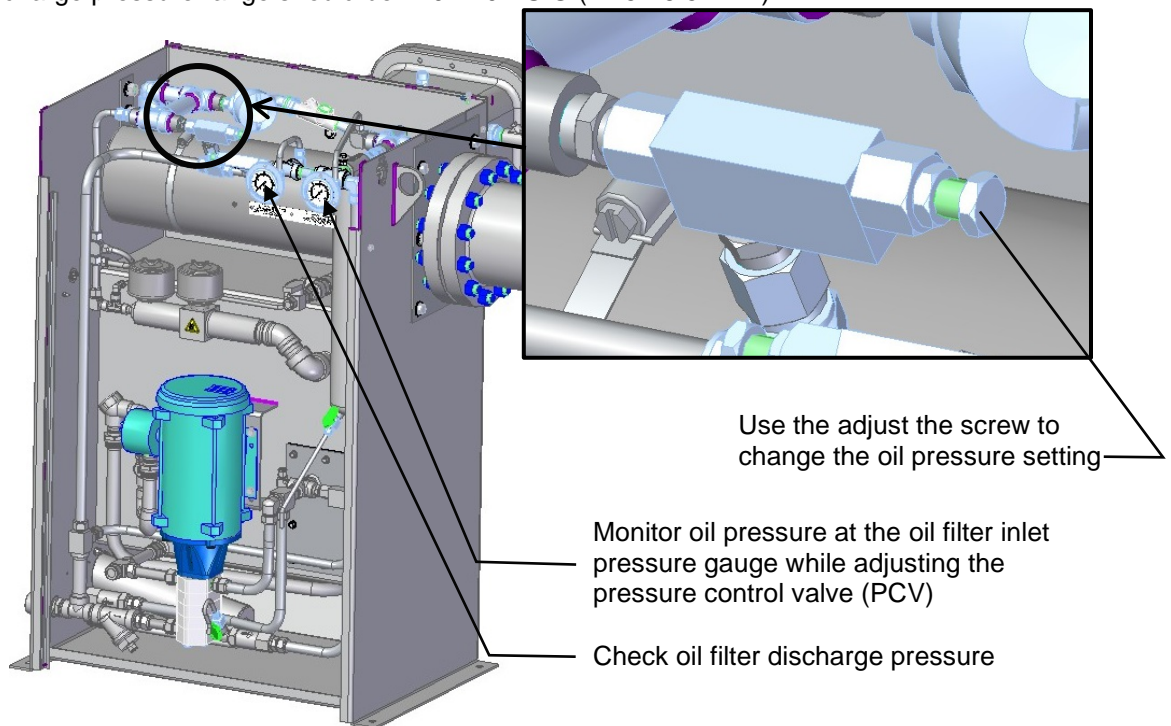

A pressure relief valve is installed on the inlet side of the oil filter. The relief valve is factory set at 290 PSIG (20 BAR). If the oil pressure will not reach 240 PSIG (16.5 BAR) the relief valve may have operated and opened. See the trouble shooting section of this manual for additional information.

System Discharge Pressure

No adjustments are necessary to the discharge pressure. Once the pressurized oil is processed through the ThermoJet Jet Mixer it enters the separation vessel where the air and removed water vapor is vented out of the system. The return oil pump takes the processed oil from the separation tank and returns it to the equipment reservoir or bulk oil supply tank being serviced. System pressure on the return oil circuit is maintained by a check valve set at 50 PSIG (3.4 BAR).

Return oil pressure can be monitored by observing the System Discharge pressure gauge.

A pressure relief valve is installed on the in the return oil circuit before the check valve. The relief valve is factory set at 270 PSIG (18.6 BAR). If the oil pressure will not reach 50 PSIG (3.4 BAR) the relief valve may have operated and opened. See the trouble shooting section of this manual for additional information.

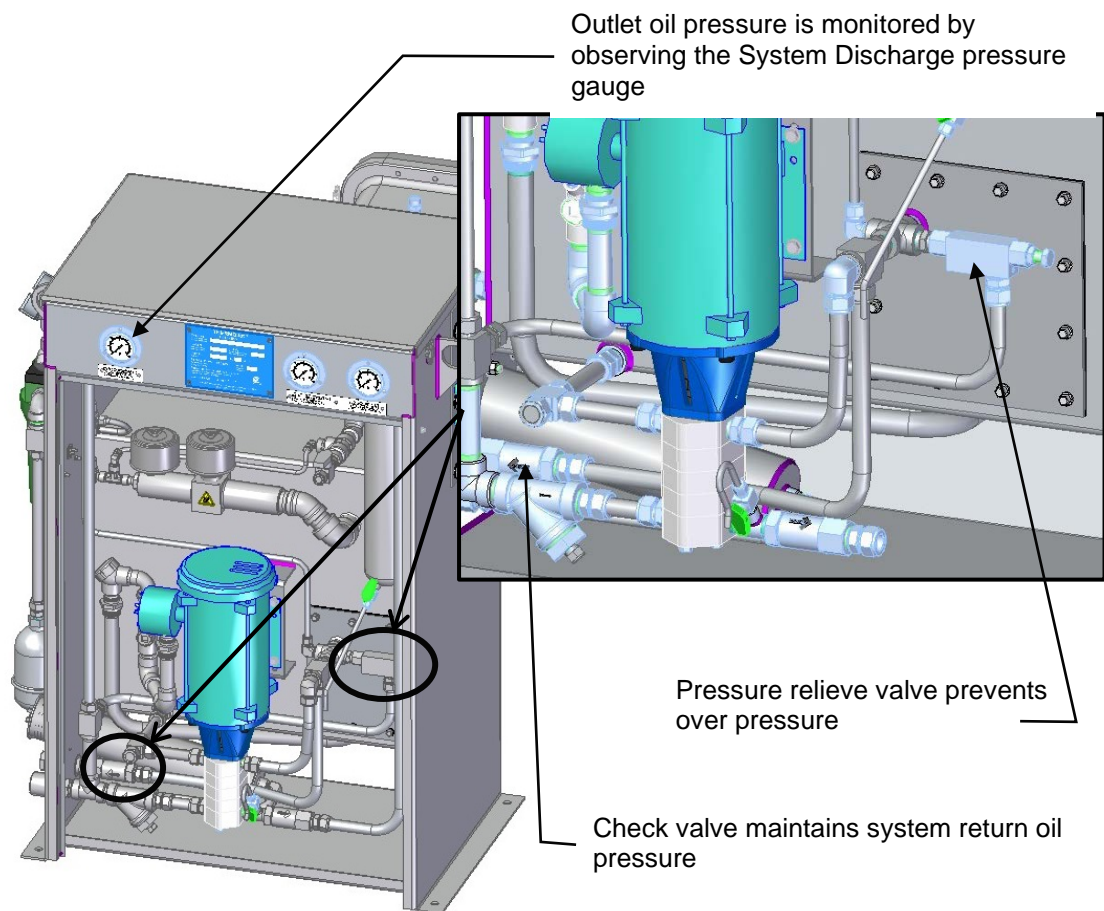

System Vent Operation

No adjustment is necessary for operation of the vent system discharge. Once the system is operating and air begins to enter the separation tank it is vented to atmosphere.

To accommodate any condensate removed by the ThermoJet while air and water vapor are exhausting, a liquid drainer is furnished to route the condensate to the condensate purifier assembly. The excess oil is removed from the condensate and the water is properly routed to the sewer system.

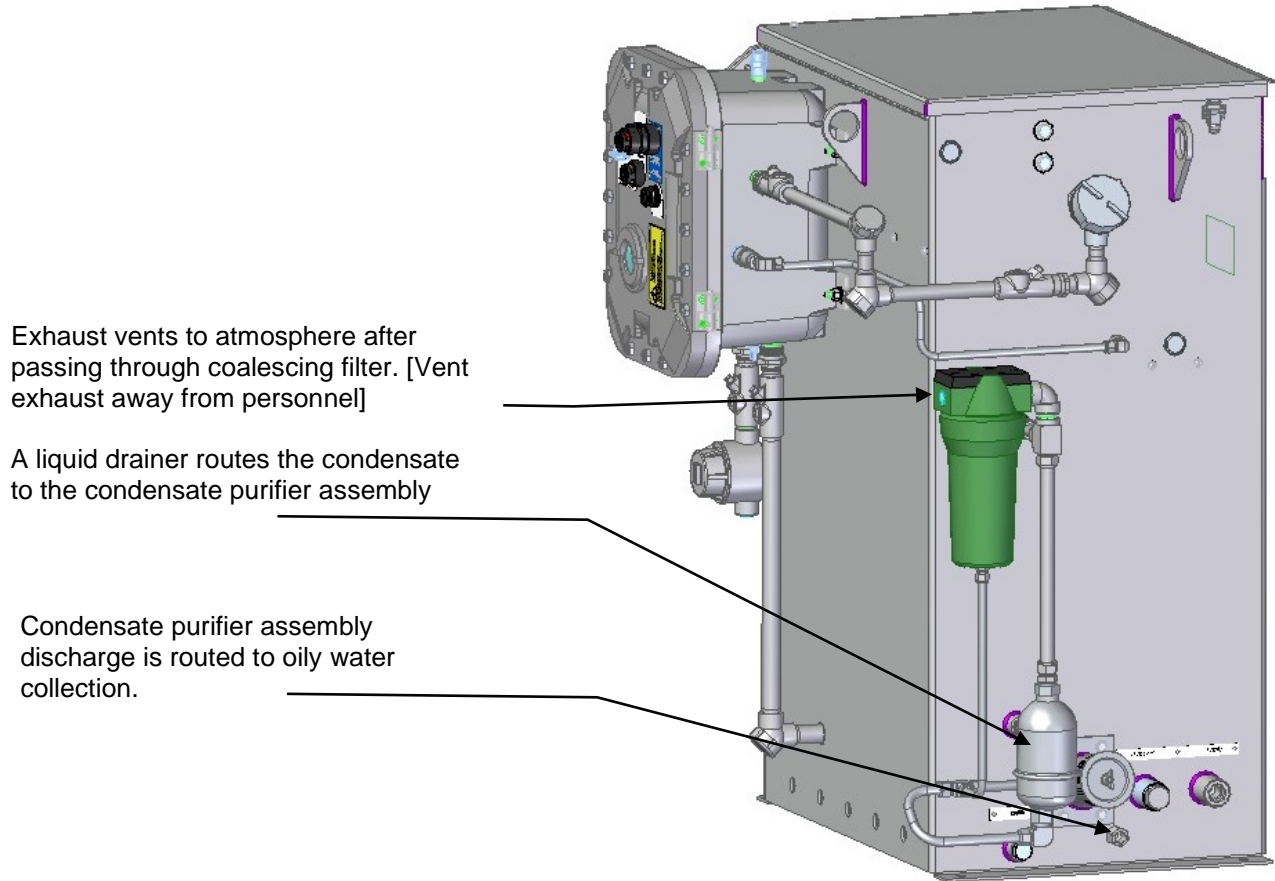

Exhaust vents to atmosphere after passing through coalescing filter. [Vent exhaust away from personnel]

A liquid drainer routes the condensate to the condensate purifier assembly

Condensate purifier assembly discharge is routed to oily water collection.

| | | |
|--|---------------|--|
| | DANGER | |
| <p>The discharge from the Condensate Purifier Assembly may be contaminated with the substances being removed from the processed oil. Ensure that the methods used to manage and dispose of these materials are in compliance with all governing authorities and plant policies and procedures.</p> | | |
| | | |



NOTICE:

Wear appropriate personal protective gear.

When cleaning oil spills consult with your lubricating oil supplier and the lubricating oil MSDS documentation regarding safe guards and Personal Protective Equipment (PPE) requirements



CAUTION

In case of oil spillage, the user or other responsible body must ensure appropriate cleanup and decontamination is carried out. Reference *CLEANING AND DECONTAMINATION* in the *ROUTINE MAINTENANCE* section of this manual.



NOTICE:

Dispose of all contaminated cleaning materials in accordance with all environmental laws, ordinances and directives. Consult your company or plant environmental protection department for disposal policy. Understand the environmental effect any used cleaning agents used and plan your cleanup accordingly.



Use environmentally friendly products and recycle where ever possible



Monitoring Normal Operation

Although the ThermoJet H2500E may be used to clean lubricants in batch operations, it is most commonly installed to clean oil in a single dedicated reservoir. The H2500E is recommended for use on oil reservoirs with a capacity of up to 2500 gallons (9500 liters). Initial and sustained oil cleanliness is maintained by continuous operation, with initial results being achieved in 8-12 “passes” after starting. The number of initial passes necessary to clean the oil in a reservoir is contingent upon the contamination level present when the system is put into service and any active ingress rate into the serviced reservoir. The time necessary for the H2500E to complete a single pass can be determined by;

$$\frac{\text{Reservoir Capacity (gallons)}}{3.2} = \text{minutes /pass}$$



NOTICE:



Verification of oil cleanliness should be verified thorough a suitable laboratory analysis.

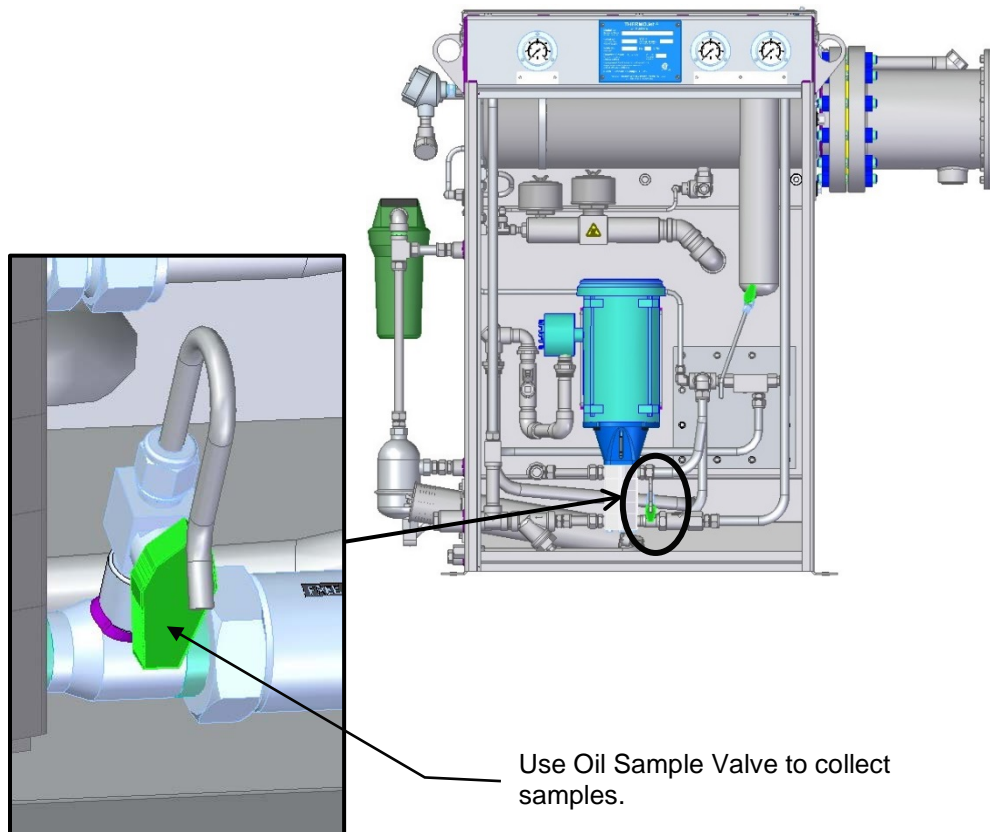

Oil samples can be collected from user installed sample points or from the oil sample valve located in the inlet pump discharge line of the ThermoJet.



Use Oil Sample Valve to collect samples.

| | | |
|---|----------------|--|
|  | WARNING |   |
| <p>When collecting oil from the sample valve, the oil will be hot and under pressure.</p> | | |

| | | |
|---|--|--|
|  | NOTICE: Wear appropriate personal protective gear when collecting oil samples. |   |
|---|--|--|

| | | |
|--|----------------|---|
|  | CAUTION |   |
| <p>In case of oil spillage, the user or other responsible body must ensure appropriate cleanup and decontamination is carried out. Reference <i>CLEANING AND DECONTAMINATION</i> in the <i>ROUTINE MAINTENANCE</i> section of this manual.</p> | | |

The daily operation of the ThermoJet system for the process operator has been reduced to monitoring and daily checks of the ThermoJet oil Purifier to emergency procedures in the event of a major malfunction. Except for emergencies, routine adjustment of the unit is not required. Any change in the Inlet Pump Discharge pressure, Filter Discharge pressure or the System Discharge pressure from the initial set points is an indication that some operational variable has changed. Care should be taken before making adjustments that might offset the failure symptoms and lead to more serious problems before detection and corrections can be made.

Keeping system adjustments to a minimum is intended to make the systems more reliable and to insure proper operation. It is not meant to discourage the natural troubleshooting initiative of the process technician. Operators should be familiar with the operating instruction of this machine, knowing how to read gauge values and alarm settings before attempting these procedures.

| | | | | |
|---|--|--|------------------------------|-----------|
|  | THERMOJET® H-2500E SERIES OIL PURIFIER SYSTEM INSTALLATION AND OPERATING MANUAL | | Doc # | 77740119 |
| | | | Rev | 15 |
| | | | Date | June 2020 |
| | | | Page 41 of 100 | |

Dailey ThermoJet Oil Purifier System Operational Checks

The following operating checks should be made daily;

- a) The normal inlet Pump Discharge pressure gauge reading is between 210 to 240 PSIG (14.5 and 16.5 BAR) at operating temperature.
- b) The normal Filter Discharge pressure gauge reading is between 210 to 240 PSIG (14.5 and 16.5 BAR).
- c) The normal System Discharge pressure gauge reading is between 50 to 100 PSIG (3.5 and 6.9 BAR) at operating temperature depending upon size/configuration of the oil return line.
- d) The temperature controller output setting gauge reading is relatively steady within 10° F of the temperature controller set point on electric heated units. The normal process temperature is between 160°-185° F.
- e) Removed water vapor is exhausting.
- f) Compare the Pump Discharge and Filter Discharge pressure gauges for the pressure difference between the two readings. If the pressure drop is approaching 25 PSID (1.7 BAR), the filter element is plugged and must be changed.

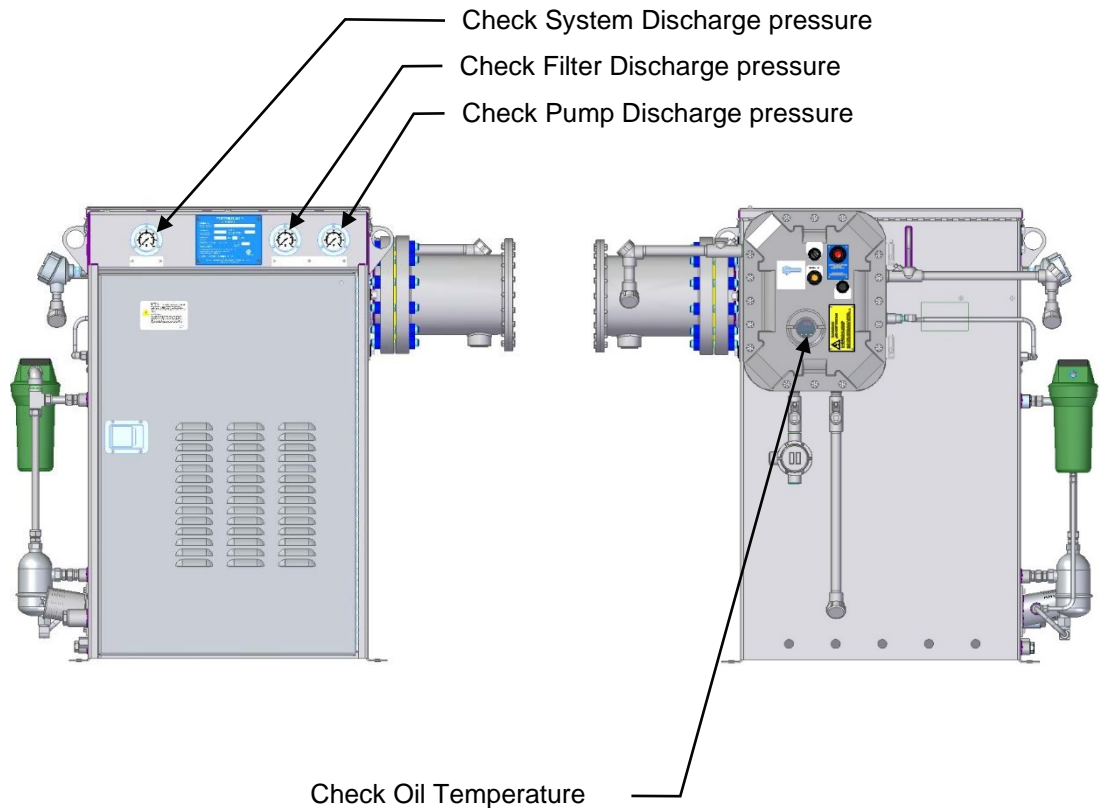

System Shutdown

ThermoJet Oil Purifiers are equipped with a timing relay which delays cessation of oil flow for 2 minutes after the power selector switch has been transferred from the ON to the OFF position. The purpose of this delay is to allow sufficient time for the oil heater to “cool down.” During this cooling interval the oil heater is inoperable and the oil temperature will decrease. At the end of the 2 minute delay the motor will stop running and the pump will cease to operated, and the oil pressure will falls to zero.

To shut down the system, 1) turn the selector switch from the ON to the OFF position, 2) allow the system to operate until the motor turns off, 3) turn the main disconnect switch from the ON to the OFF position.

1) Turn ON-OFF Selector Switch to OFF position

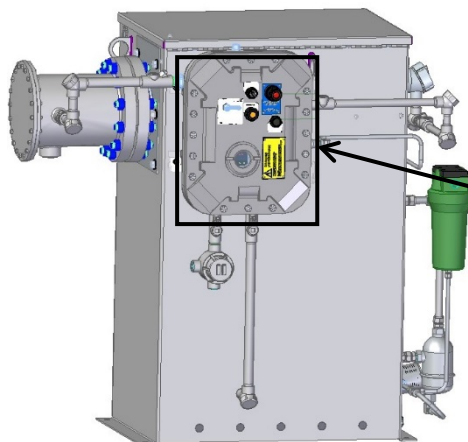

3) Once system shuts down and pressure falls to zero, Turn Main Disconnect Switch to OFF Position

2) Heater ceases to operate. Heater ON pilot light remains OFF as Oil circulates to cool down. After 2 minutes the system will automatically turn OFF

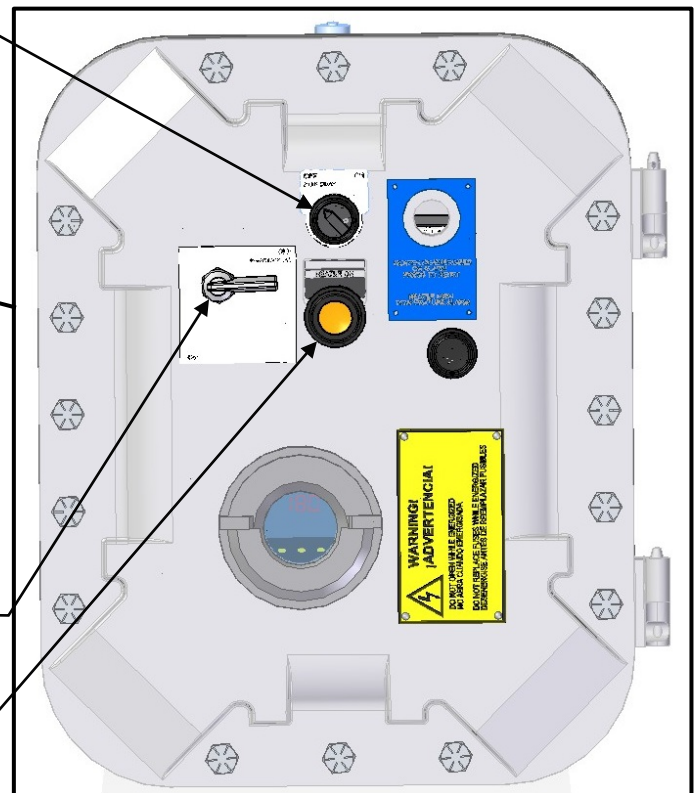

If the unit is turned OFF for system maintenance, see the section of this manual titled *ROUTINE MAINTENANCE*. If the unit is being decommissioned see the section of this manual titled *REMOVAL FROM USE, DISPOSAL AND TRANSPORT*



NOTICE:

For EMERGENCY SHUT DOWN switch the main circuit breaker handle to OFF position.

VI ROUTINE MAINTENANCE



NOTICE:

Only a qualified person should make replacement of spare parts.



WARNING

Before performing maintenance tasks ensure that the area is clear of all hazardous or explosive gases or materials, and that a **HOT WORK PERMIT** or other authorization to work has been issued and posted according to all facility standards and procedures. Where required, area monitoring and alert systems and process must be in place and in operation during the performance of work.



Observe all local and state laws and restrictions.



Failure to do so may result in explosion and loss of property, serious injury or even loss of life.





Maintenance Checks

To insure proper system operation the following maintenance procedures should be performed according to the schedule indicated below. If the any interim abnormal operating condition is observed on a shorter than indicated interval, maintenance actions should be executed as those conditions are observed. If your operating conditions are considered to be in an extremely dusty or humid environment, the maintenance schedule should be accelerated. Consult with the nearest manufacturing office/service center for further discussion and recommendations.

| | | |
|--|---------------|---|
|  | DANGER |  |
| <p>The oil in the ThermoJet Oil Purifier and its subassemblies may be contaminated with the substances being removed from the processed oil. Ensure that the methods used to manage and dispose of these materials are in compliance with all governing authorities and plant policies and procedures.</p> | | |

| | | |
|--|--|--|
|  | <p>NOTICE: Wear appropriate personal protective gear.</p> <p>When cleaning oil spills consult with your lubricating oil supplier and the lubricating oil MSDS documentation regarding safe guards and Personal Protective Equipment (PPE) requirements.</p> |  |
|--|--|--|

| | | |
|---|----------------|---|
|  | CAUTION |  |
| <p>The oil filter will be filled with contaminated oil. Ensure that the container used for receiving the drained oil and other fluids is sufficiently large to avoid spills.</p> <p>In case of oil spillage, the user or other responsible body must ensure appropriate cleanup and decontamination is carried out. Reference <i>CLEANING AND DECONTAMINATION</i> in the <i>ROUTINE MAINTENANCE</i> section of this manual.</p> | | |





WARNING



Contents in this system are under pressure while operating. Surfaces and contents may be HOT. Once the system has been shut down allow sufficient time for cooling before servicing this equipment.





NOTICE:

Dispose of all contaminated cleaning materials in accordance with all environmental laws, ordinances and directives. Consult your company or plant environmental protection department for disposal policy. Understand the environmental effect any used cleaning agents used and plan your cleanup accordingly.

Use environmentally friendly products and recycle where ever possible



| Schedule for Routine Maintenance Checks and Tasks | | | |
|--|-------------|--------|---|
| Maintenance Task | Semi Annual | Annual | Maintenance Spare Parts Needed |
| General Inspection | X | | |
| Oil Filter Maintenance | X | | p/n 19103006 Filter Element p/n 40520235 O-ring <R13> |
| Y-Strainer Maintenance | X | | p/n 49002078 Gasket |
| Condensate Purifier Assembly Maintenance | X | | p/n 19201002 Oil Absorption Sock |
| Oil Mist Eliminator Maintenance | | X | p/n 77750101 Filter Element |
| Air Breather Maintenance | X | | |
| Separation Vessel Maintenance | X | | p/n 40511031 Gasket |
| Oil Heater Maintenance | | X | p/n 40500060 Flange Gasket, 6 Inch |
| Auto Tune Oil Heater Controller | | X | |
| Check and Adjust Operating Pressures | X | | |
| Verify Low Oil Pressure Switch Operation | X | | |
| Verify Oil Heater High Temperature Cutout Operation | X | | |

| | | | | |
|--|--|--|------------------------------|-----------|
|   | THERMOJET® H-2500E SERIES OIL PURIFIER SYSTEM INSTALLATION AND OPERATING MANUAL | | Doc # | 77740119 |
| | | | Rev | 15 |
| | | | Date | June 2020 |
| | | | Page 46 of 100 | |

General Inspection

Prior to performing routine maintenance task a general inspection should be made for the overall operating condition of the ThermoJet Oil Purifier and system. A list of items to be checked is provided below. When necessary, this list should be expanded to include additional check points applicable to your particular installation that are important in assuring proper and continuous and safe operation.

- Check and record all pre-service system operating conditions;
 1. Oil temperature
 2. Inlet oil pressure
 3. Outlet pressure
 4. Pump discharge pressure
- Check over all condition of the cabinet, cabinet door and hinged cover operation.
- Check interior of cabinet for leaks and oil spills.
- Check oil supply and return piping and / or hoses for leaks.
- Check condition of all pressure gauges.

Oil Filter Maintenance

Check the inlet pump discharge and filter discharge pressure gauges for the pressure loss between the two readings. If the pressure loss is approaching 25 PSID (1.7 BAR), the filter element is plugged and must be changed. The filter element should be changed when the pressure loss is 25 PSID (1.7 BAR)

To change the filter element, first shut down the ThermoJet. See the section titled *Shut Down Procedures* on how to turn the ThermoJet Oil Purifier OFF.

Remove the vent plug located on top of the filter housing to prevent the siphoning of oil out of the heater tube.

Open the drain valve at the bottom of the filter housing and allow the oil to drain into a suitable container.

Turn the locking ring on the filter housing counter-clockwise using the supplied wrench that is attached to the filter housing until the housing is loose. Drop the filter housing down from the filter head. Clean the interior of the filter housing by use of a safe solvent and/or wiping with a lint free cloth. Install a new oil filter (p/n 1910-3006) and O-ring (p/n 4051-1031).

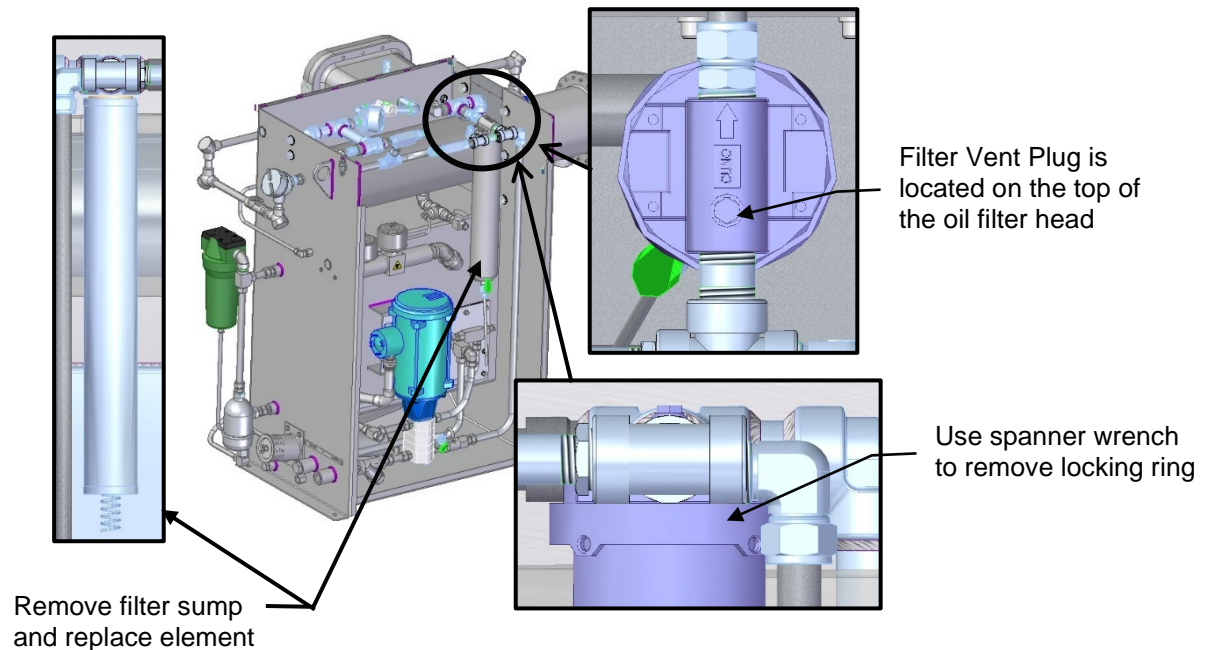

Reinstall the filter housing and using the spanner wrench to tighten and secure the filter housing with the lock-nut.

Reinstall the vent plug on top of the filter housing and ensure that the drain valve on the bottom of the filter housing is closed.

See the sections of this manual titled *Cleaning and Decontamination* and *Removal from Use, Disposal and Transport* for additional information.

Y-Strainer Maintenance

To check and clean the suction screen in the Y Strainer, first shut down the ThermoJet. See the section titled *Shut Down Procedures* on how to turn the ThermoJet Oil Purifier OFF.

Close and tag the nearest oil block valve to the ThermoJet oil inlet and outlet connection.

To drain the collected contents that have been collected in the Y-strainer basket, you only need to remove the small plug from the bottom of the strainer. Collect and properly dispose of all collected contents.

To remove and clean the strainer screen, remove the large plug. The suction screen along with the dirty oil and particulate can be removed from the bottom of the strainer. Collect and properly dispose of all collected contents. Clean the suction screen by washing and flushing. The use of a brush may be necessary to remove small particulate for the screen mesh. Check the plug seal and replace if necessary.

Once cleaning is completed, install the suction screen into the bottom of the Y-strainer body, using the plug to hold in place. Ensure that the plug is tight to avoid leaks or pump cavitation when restarting the machine.

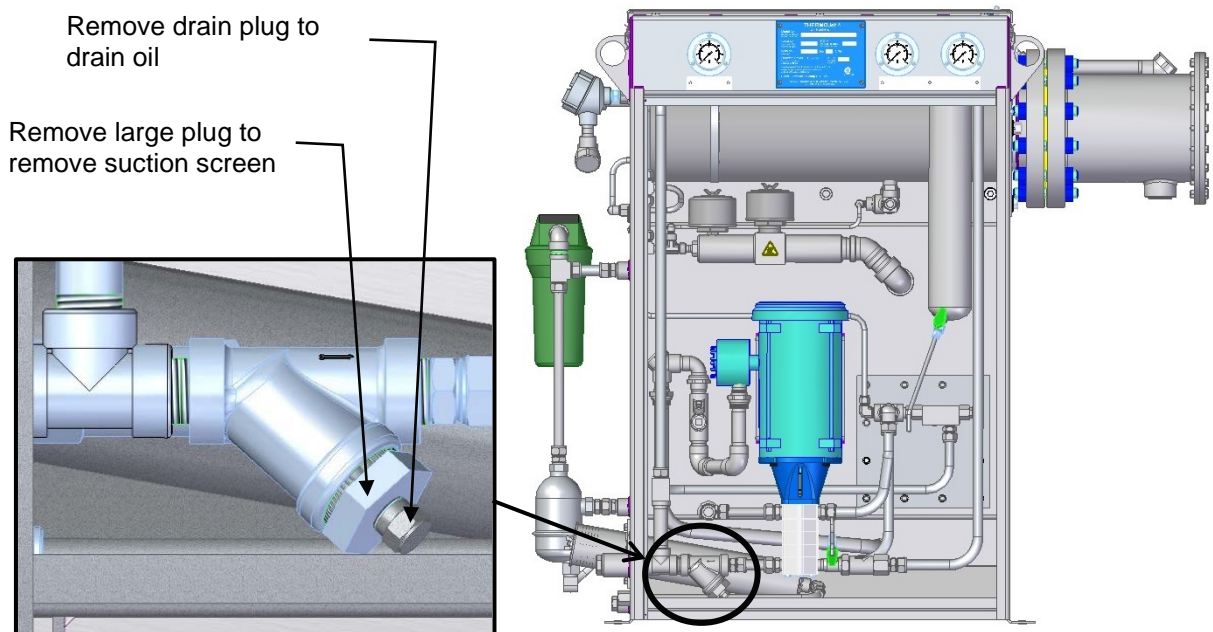

Condensate Purifier Assembly Maintenance

Maintaining and replacing the oil absorption media in the Condensate Purifier Assembly (CPA) can be done while the ThermoJet is operating.

Replace oil absorption media sock if saturated. This absorption media sock should remain effective for two to four weeks. Periodic visual inspection is the only way to determine if sock is saturated.

To replace the absorption media sock locate the cover cap on the CPA housing. Remove the cap and pull the media out of the housing.

Inspect the interior of the housing and clean as necessary. Install a new absorption media sock and re-install the cover cap.

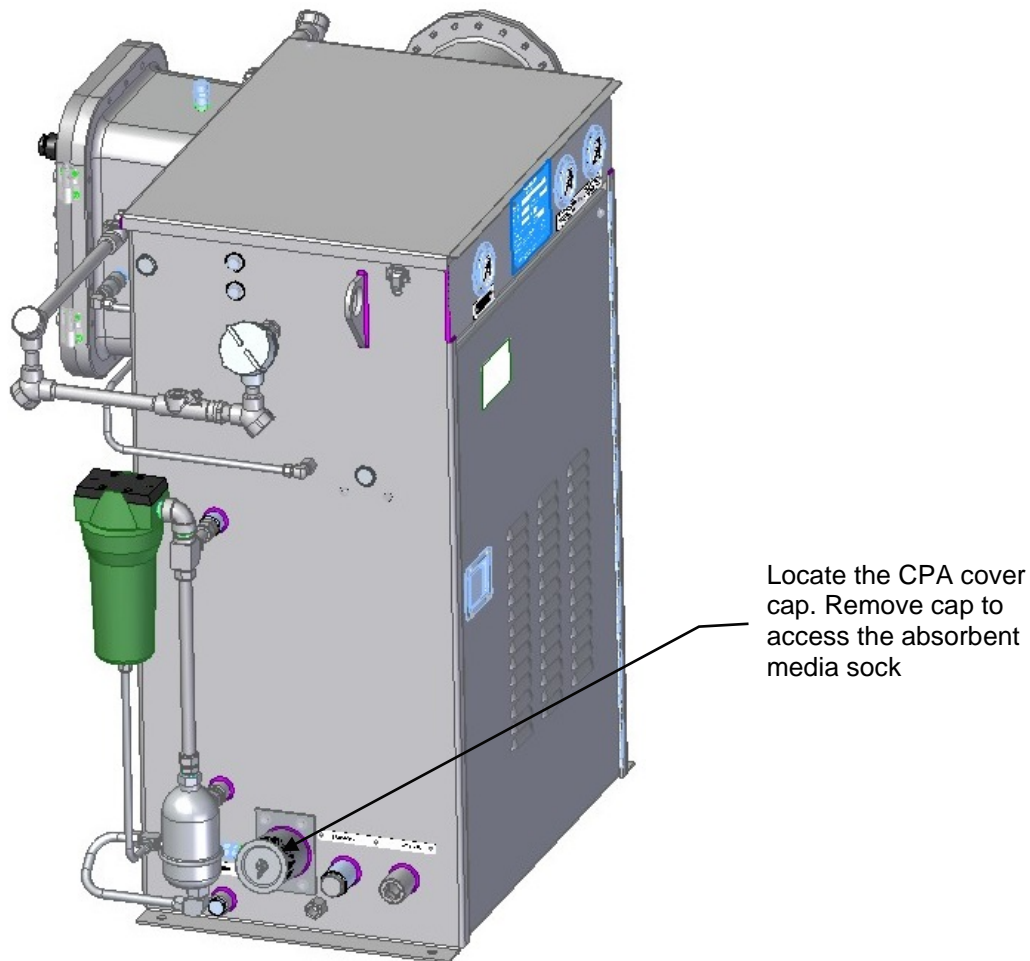

Oil Mist Eliminator Maintenance

The ThermoJet Oil Purifier must be shut down before performing maintenance on the oil mist eliminator. The oil mist eliminator is located on the left side of the unit. Maintenance involves removing and cleaning the oil filter housing and replacing the filter element.

First shut down the ThermoJet. See the section titled *Shut Down Procedures* on how to turn the ThermoJet Oil Purifier OFF.

Close and tag the nearest oil block valve to the ThermoJet oil inlet and outlet connection.

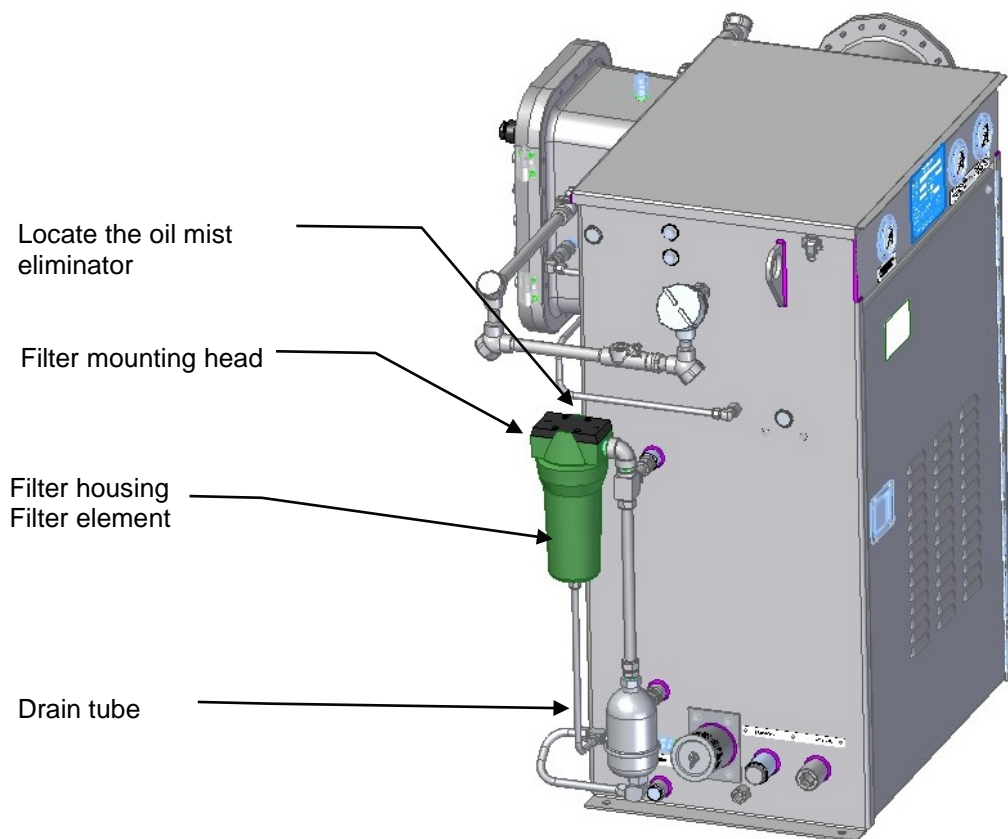

To remove the filter housing first remove the drain tube from the bottom of the filter housing. Next firmly grasp the filter housing with both hands and lift upward and turn to the left (Clock wise). The filter housing can then be lowered away from the filter mounting head. To remove the filter element grasp and pull down. The filter element will slide off of the filter mounting nipple.

Inspect the interior of the filter housing and wipe clean as necessary. Check the drain tube to insure that it is clear and unobstructed. Install a new filter element by sliding onto the mounting nipple. Replace the filter housing by sliding it over the newly installed element, then pushing it upward against the bottom of the filter mounting head and turning to the right (C-Clock wise). Reinstall the drain tube to the bottom at the bottom of the oil mist eliminator.



Air Breather Maintenance

There are two inlet air breathers located on top of the jet mixer. The jet mixer is inside of the ThermoJet Model H2700E console cabinet. This maintenance operation involves removing and cleaning the screens in both air breathers and then reinstalling them on the jet mixer.

| | | |
|--|----------------|---|
|  | WARNING |  |
| <p>Contents in this system are under pressure while operating. Turn the ThermoJet Oil Purifier OFF before servicing.</p> <p>Surfaces and contents are HOT. Once the system has been shut down allow sufficient time for cooling before servicing this equipment.</p> | | |
| | |  |

To access the inlet air breathers, open the cabinet door and locate the jet mixer. The inlet air screens are located on top of the jet mixer.

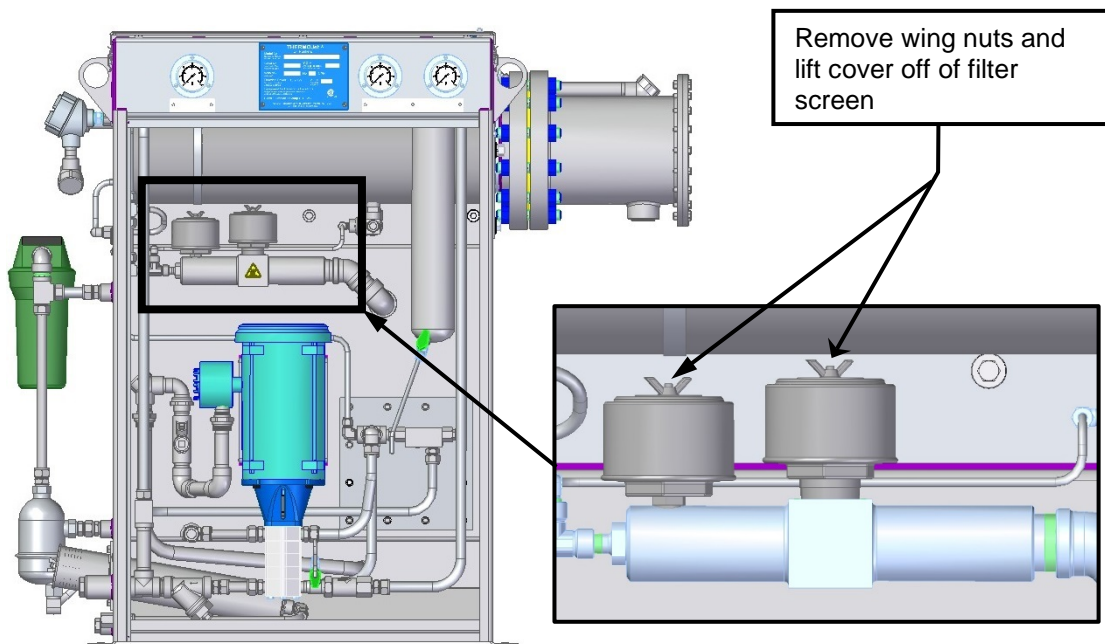

To access the air filter screens, remove the wing nuts from the top of the air breathers and lift the covers from the assembly. Remove the filter screens and clean. Once the filter screens are clean, reinstall them and replace the covers and wing nuts.

Separation Vessel Maintenance

The ThermoJet Oil Purifier must be shut down before performing separation vessel. This maintenance operation involves removing the separation inspection cover plate and cleaning the interior of the separation vessel. The inspection cover plate is located on the interior of the ThermoJet Model H2500E console cabinet.

First shut down the ThermoJet. See the section titled *Shut Down Procedures* on how to turn the ThermoJet Oil Purifier OFF.

Close and tag the nearest oil block valve to the ThermoJet oil inlet and outlet connection.



First drain all oil from the separation vessel and the inlet oil filter. A drain plug is located in the outlet pump suction line between the separation vessel outlet and the pump suction for draining the separation vessel. Use the drain valve located at the bottom of the inlet oil filter vessel for draining the oil filter. For additional information on draining the oil from the oil filter see the section in this manual titled *Oil Filter Maintenance*. Use a pail to gather the oil. See the sections of this manual titled *Cleaning and Decontamination* and *Removal from Use, Disposal and Transport* for additional information.

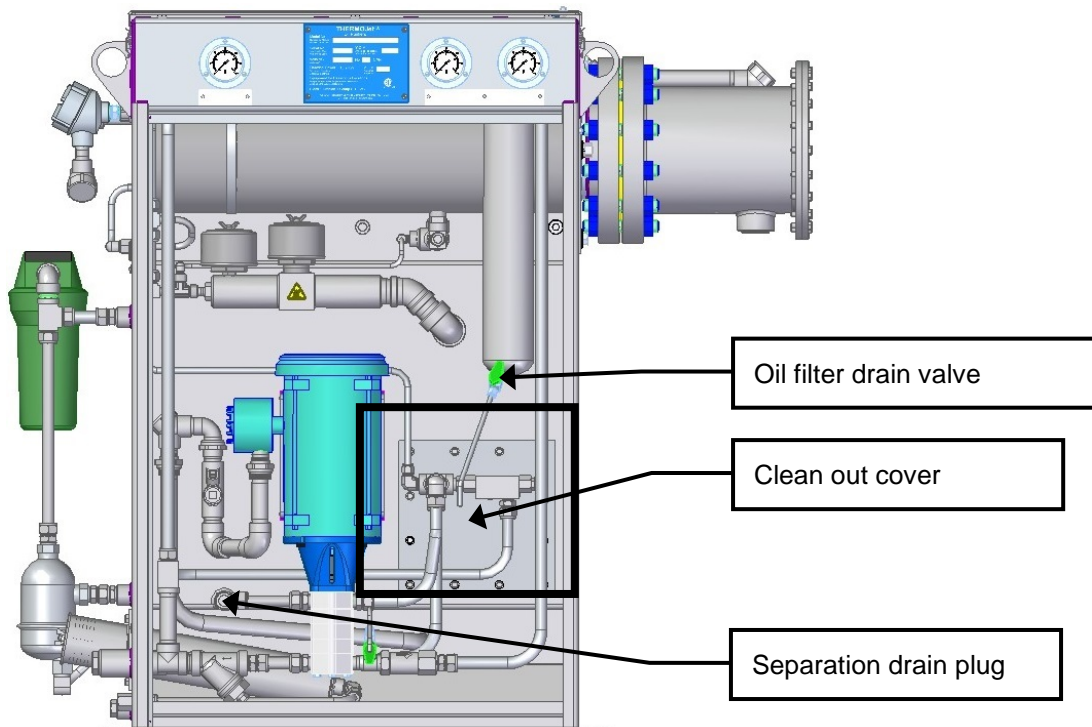

There are six stainless steel tubes that are connected to the separation vessel clean out cover that restrict immediate access that must first be removed. These are 1) oil outlet tube to the oil outlet connection 2) oil supply tube from the outlet pump 3) oil pressure relief tube from the outlet pump pressure limiting valve 4) oil supply tube between the inlet pump and in oil filter 5) the drain tube connected to the oil filter drain valve and 6) oil pressure tube to the outlet oil pressure gauge

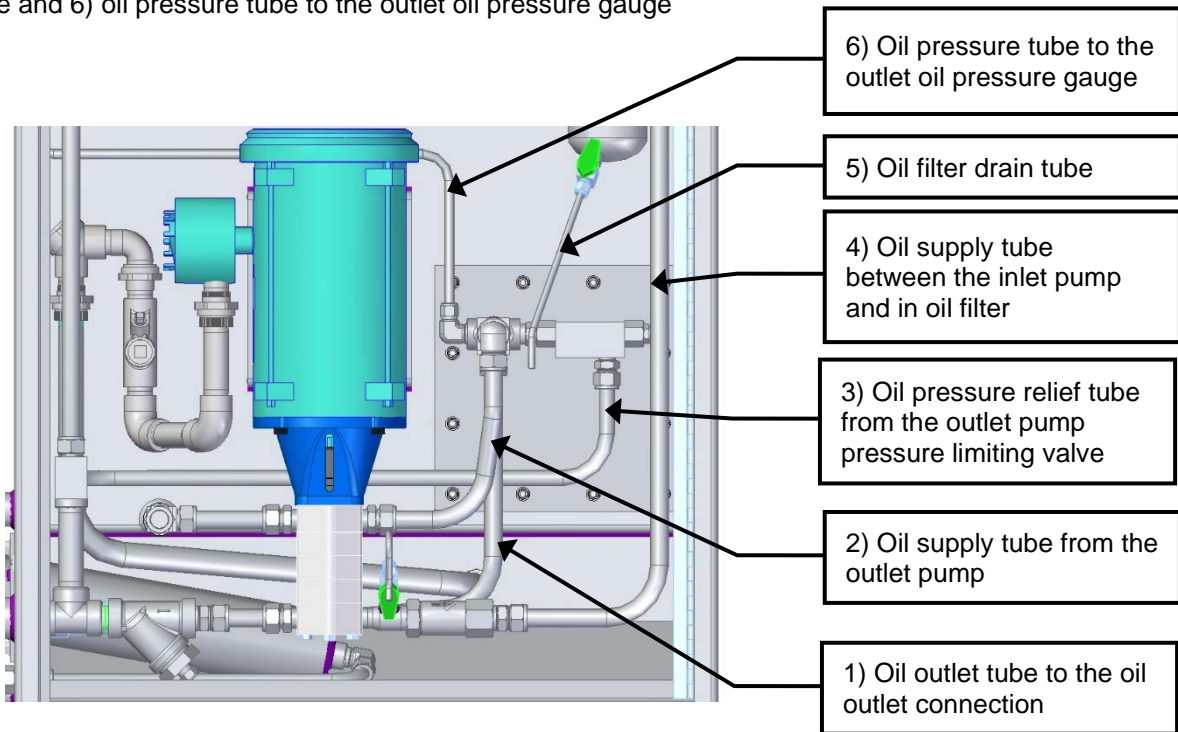

Once all tubing has been removed remove the separation vessel cover plate from the vessel. The cover plate is secured in place with twelve socket head screws. Remove the screws and set aside for reuse. Lift the cover plate from the separation vessel. Note that the oil level control valve is mounted to the rear of the cover plate.

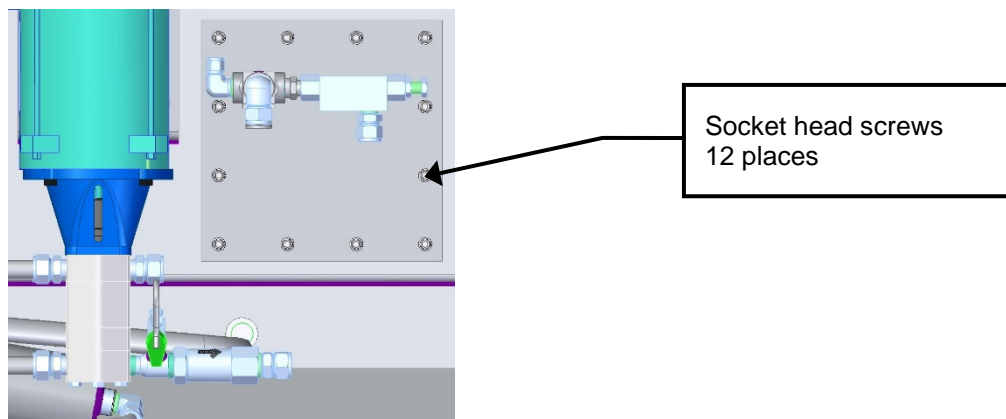

| | | | | |
|---|--|--|------------------------------|-----------|
|  | THERMOJET® H-2500E SERIES OIL PURIFIER SYSTEM INSTALLATION AND OPERATING MANUAL | | Doc # | 77740119 |
| | | | Rev | 15 |
| | | | Date | June 2020 |
| | | | Page 54 of 100 | |

Once the cover plate and level control valve has been removed inspect the interior of the separation reservoir and clean using a lint free rag. See the sections of this manual titled *Cleaning and Decontamination* and *Removal from Use, Disposal and Transport* for additional information.

Inspect the oil level control valve for operation and by lifting the float. The valve should operate smoothly without hanging or sticking as the float moves over its operation range.

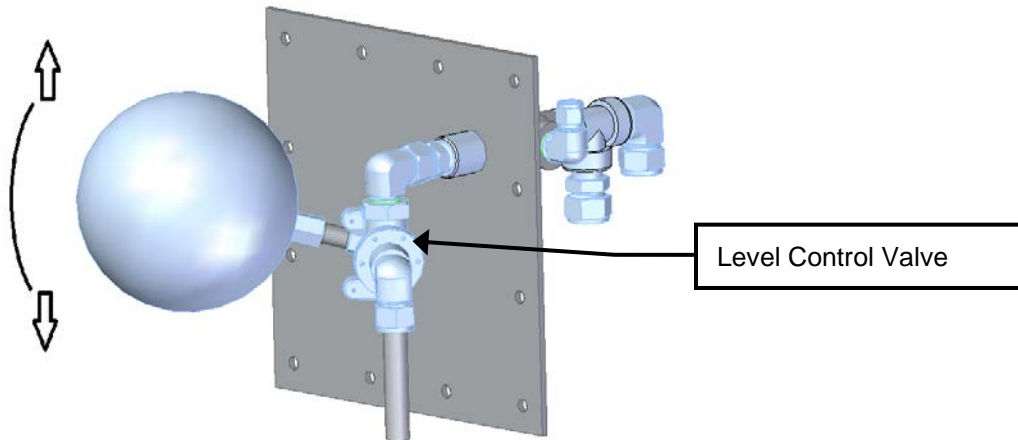

If the level control valve sticks or does not operate smoothly, it should be replaced.

Use part number 51850100 VALVE, LEVEL CONTROL.



IMPORTANT NOTE:
When disassembling the level control valve from the clean out cover, make note of the valve and float orientation. It must be assembled in the same position in order to properly operate and fit into the separation vessel.

Once all parts are inspected and determined to be in proper working order, reassemble the clean out cover onto the separation vessel using a new gasket and the screws from disassembly.

Use replacement part number 40511031 GASKET, OIL LEVEL CONTROL PLATE - VITON

Reinstall all tubing as disassembled. Insure that all connections are tight.



Reinstall the reservoir drain plug

Ensure that the filter drain valve is in the closed position.

Oil Heater Maintenance

The ThermoJet Oil Purifier must be shut down before performing oil heater maintenance. The oil heater is located on the right side of the unit. Maintenance involves removing the oil heater bundle for inspection and cleaning of the oil heater vessel.

| | | |
|---|---|---|
|  | <div style="background-color: red; color: white; padding: 5px; border-radius: 15px; font-weight: bold; font-size: 1.2em;">WARNING</div> <p>Surfaces and contents are HOT. Once the system has been shut down allow sufficient time for cooling before performing this maintenance task.</p> |  |
|---|---|---|

| | | |
|---|---|---|
|  | <div style="background-color: red; color: white; padding: 5px; border-radius: 15px; font-weight: bold; font-size: 1.2em;">DANGER</div> <p>Ensure that electrical power is turned OFF and all electrical circuits serving this machinery have been locked out and tagged out before performing this maintenance operation. Failure to do so may result in serious injury, loss of property or even death.</p> |  |
|---|---|---|

Before performing this maintenance task, first shut down the ThermoJet. See the section titled *Shut Down Procedures* on how to turn the ThermoJet Oil Purifier OFF.

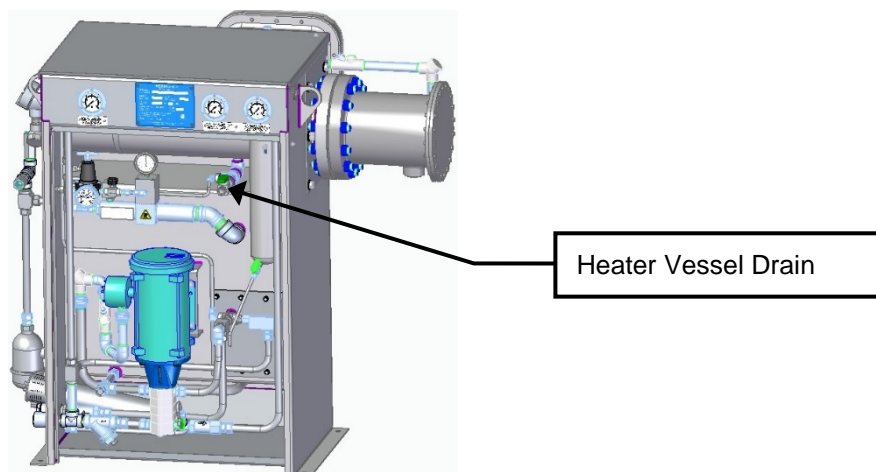

Close and tag the nearest oil block valve to the ThermoJet oil inlet and outlet connection.

Next ensure all of the oil has drained from the oil heater vessel. The heater vessel drain is located on the interior of the ThermoJet H2500E cabinet. Remove the closure cap from the drain valve and set aside. Using a pail to gather the oil, open the drain valve located at the bottom of the heater vessel and collect the oil. The heater internal oil volume of the heater vessel is approximately 3.9 gallons (14.8 liters). See the sections of this manual titled *Cleaning and Decontamination* and *Removal from Use, Disposal and Transport* for additional information.

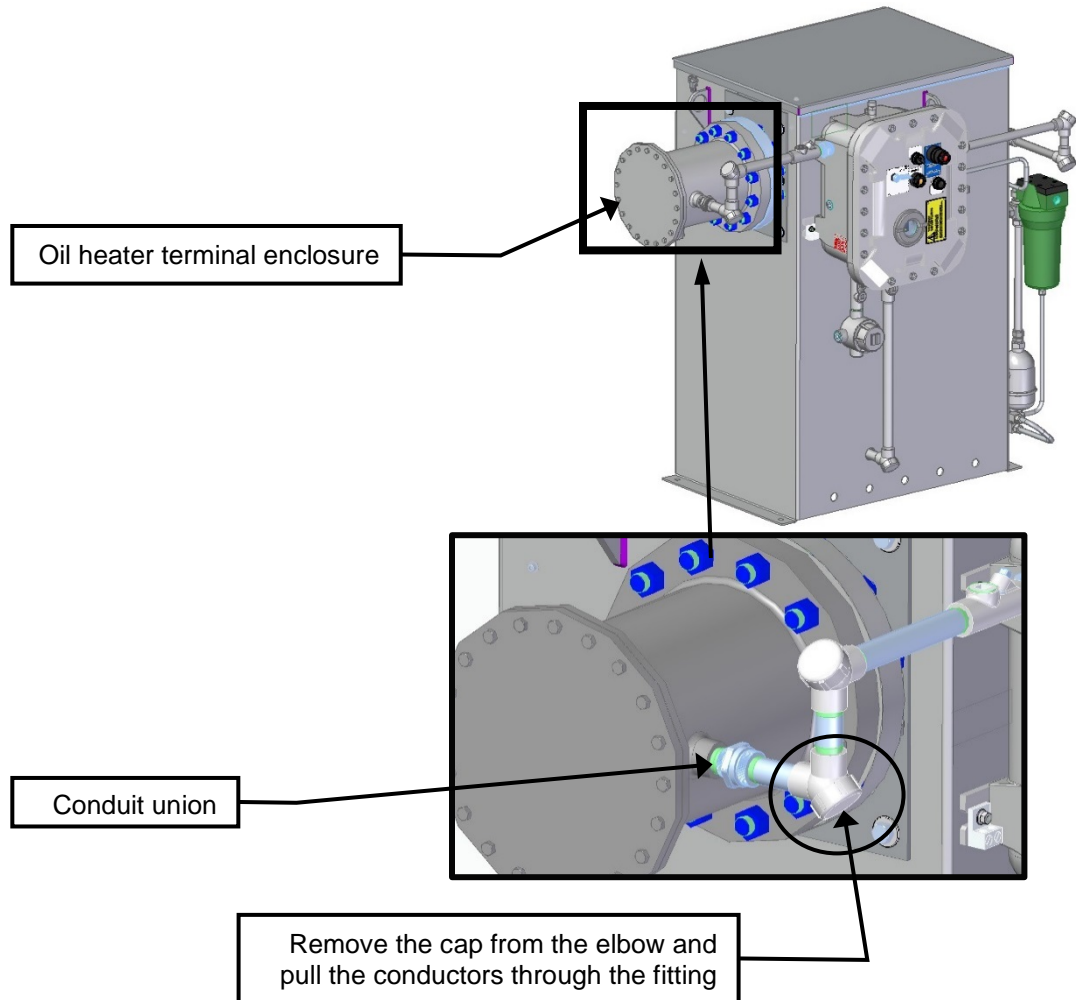

Once electrical power has been removed and locked out from the unit, open the electrical terminal enclosures for the oil heater and disconnect the power wires from the terminals. Remove the cap from the first conduit elbow adjacent to the heater enclosure and pull all of the conductors through the conduit so that they are out of the way of the conduit union. Loosen the conduit union and separate the two halves of the fitting so that the heater bundle can be removed.



| | | |
|--|----------------|---|
|  | WARNING |  |
| <p>Use suitable transport equipment for removing the heater bundle from the heater vessel, lifting and re-installing the heater into the heater vessel. Ensure that the heater is secured prior to and during lifting and transport. Stand clear of the all equipment while being maneuvered. Crane and fork truck operators should be properly trained in there operation.</p> | | |
| <p>Heater approximate weight is 185 pounds (84 Kg)</p> | | |
| | |  |

**NOTICE:**

When removing the oil heater bundle from the heater vessel, the end of the vessel will be open. Care should be taken to avoid, minimize and control oil spills.

Consult with your lubricating oil supplier and the lubricating oil MSDS documentation regarding safe guards and Personal Protective Equipment (PPE) requirements.

See the sections of this manual titled *Cleaning and Decontamination, Removal from Use, Disposal and Transport and Draining and Cleaning Procedures* for additional information



Attach a suitable lifting strap to the heater tube at the two lifting eye bolts in the heater flange. Remove all of the slack from the lifting strap so as to provide support for the heater as it is unbolted from the heater vessel flange, but taking care not to apply excess tension. Remove the flange studs and nuts from the heater that secure it to the heater vessel. Once the heater bundle is free from the heater vessel, remove it and set aside.

**CAUTION**

Take care to guard against pinching and crushing hazards when handling the heater bundle.



Inspect the heater for coking and for cracked or split elements. Clean the heater bundle to remove any residue or contamination that may have entered the heater vessel.

Inspect the interior of the heater vessel and wipe clean with a lint free cloth.

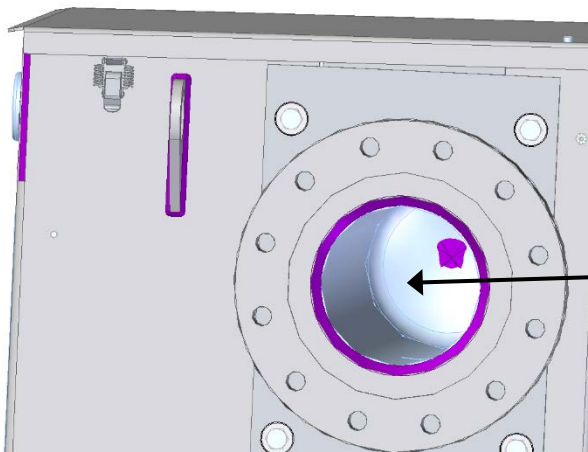

Inspect and clean the interior of the heater vessel

Remove the drain tubing between the heater tube and the inlet of the jet mixer. Remove the elbow at the heater vessel end and inspect the drain orifice. Insure that the drain orifice is clear. Clear and clean any debris if necessary.

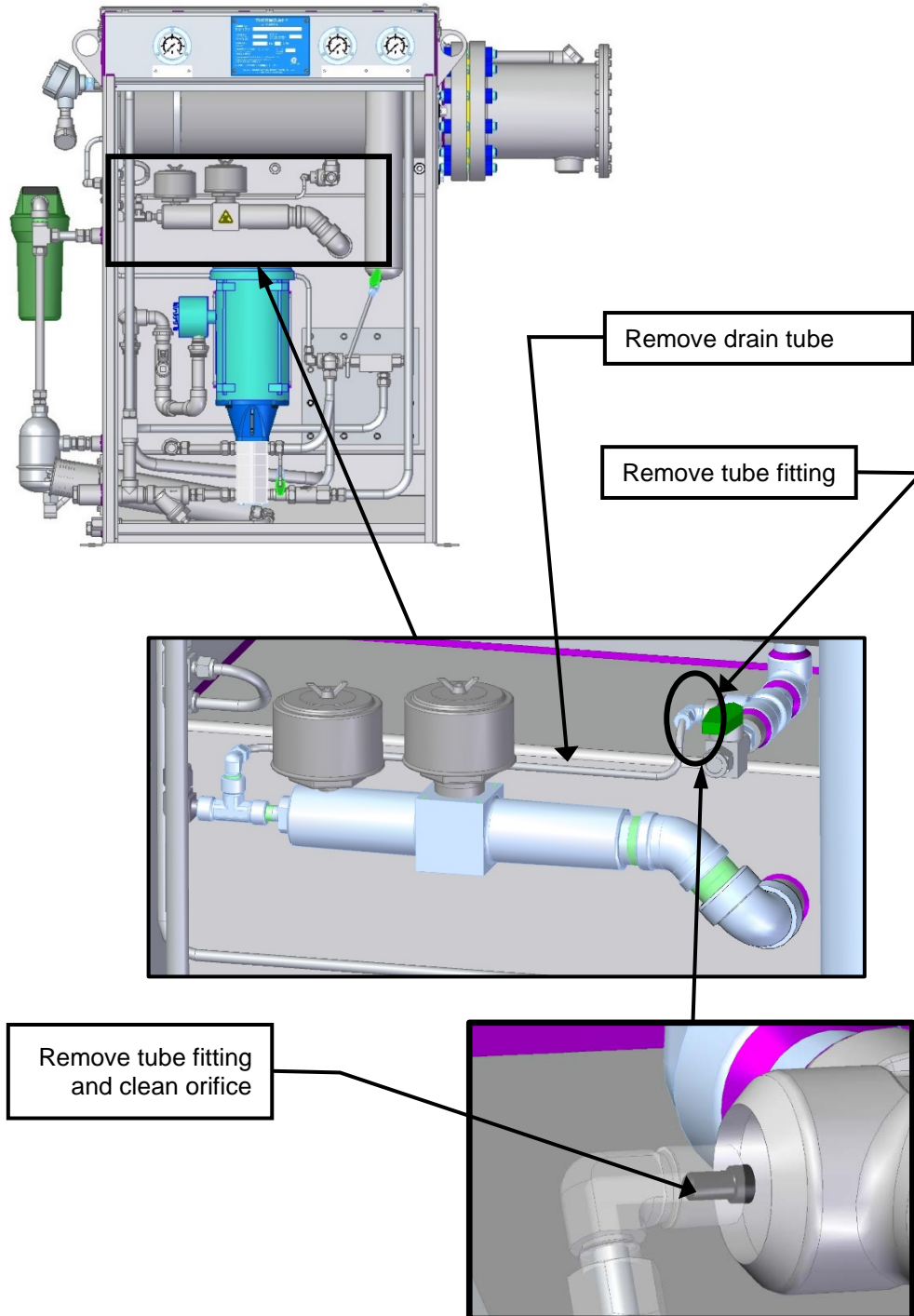

Once inspection and cleaning is complete reinstall the tube fitting with drain orifice and the drain tubing from the bottom of the heat tube and the jet mixer

With a new flange gasket, use the flange studs and nuts to install the heater bundle into the heater vessel. Gasket p/n 40500060



CAUTION



Take care to guard against pinching and crushing hazards when handling the heater bundle.



WARNING



Use suitable transport equipment for removing the heater bundle from the heater vessel, lifting and re-installing the heater into the heater vessel. Ensure that the heater is secured prior to and during lifting and transport. Stand clear of the all equipment while being maneuvered. Crane and fork truck operators should be properly trained in there operation.
Heater approximate weight is 84 Kg (185 pounds)



Reinstall and align the conduit and tighten the conduit union to secure the conduit to the heater terminal enclosures. Connect the power wiring to the heater terminals. Reinstall terminal cover.



NOTICE:
All electrical connections should only be made by a qualified personnel.



WARNING



Ensure that all enclosure covers are securely installed.

Install the cap on the drain valve in the bottom of the heater vessel and insure that the drain valve is in the close position.

Auto Tune Oil Heater Controller



The ThermoJet Oil Purifier must be running and operating normally in order to perform this maintenance task.

| | | | |
|--|----------------|---|---|
|  | WARNING |  | |
| <p>Before performing this maintenance task ensure that the area is clear of all hazardous or explosive gases or materials, and that a HOT WORK PERMIT or other authorization to work has been issued and posted according to all facility standards and procedures. Where required proper monitoring and alert systems and process must be in place and in operation during the performance of work. Observe all local and state laws and restrictions. Failure to do so may result in explosion and loss of property, serious injury or even loss of life.</p> | | |  |

To access the heater controller, unthread the enclosure cover it from the base.

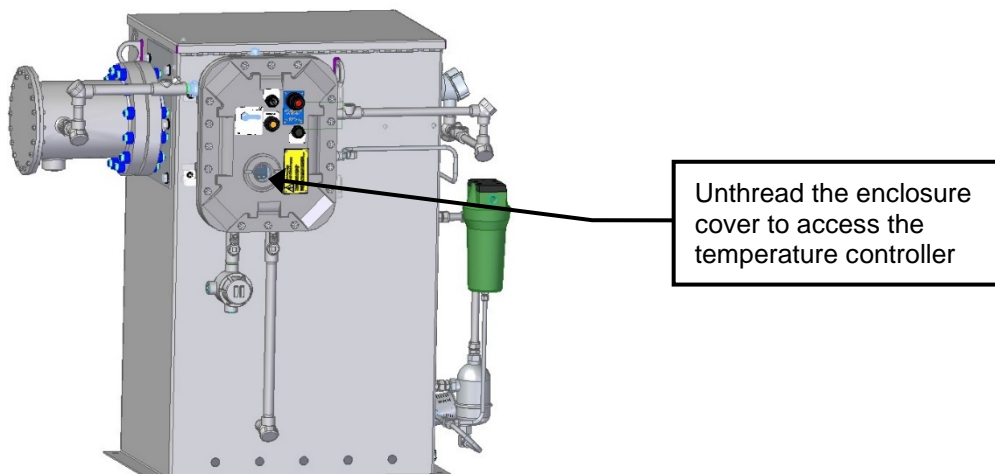
| | |
|--|----------------|
|  | CAUTION |
| <p>Care should be taken when removing and reinstalling the controller enclosure so prevent damage to any flame proof joint, such as between the enclosure and the treaded cover. Flameproof joints are not to be repaired in the field. If the flame path is damaged the enclosure is to be removed from service and replaced with a new properly working enclosure.</p> | |



With the controller set point set to the normal operating temperature (82°C / 180° F) press   until A_t ---- appears on the display.

Press  for at least 3 seconds. The upper display will begin to flash and the auto-tuning process begins.

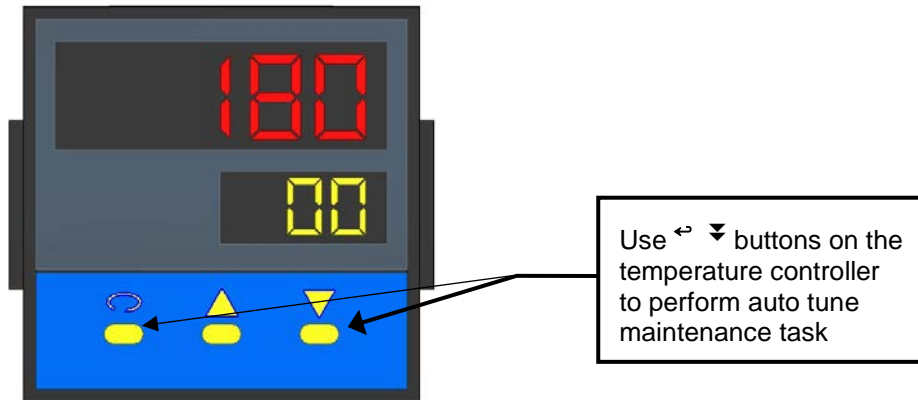

Once the auto tune process is completed the process display will cease to flash and the unit will revert to normal operation. Insure that the oil temperature operates at the prescribed operating temperature and make adjustments as required. Reference the section of this manual in the V SYSTEM START-UP AND OPERATION section of this manual titled *Heater Operation*.

Once the auto tune maintenance is completed, reinstall the controller cover.





| | | | | |
|---|--|--|------------------------------|-----------|
|  | THERMOJET® H-2500E SERIES OIL PURIFIER SYSTEM INSTALLATION AND OPERATING MANUAL | | Doc # | 77740119 |
| | | | Rev | 15 |
| | | | Date | June 2020 |
| | | | Page 62 of 100 | |

Check and Adjust Operating Pressures

The ThermoJet Oil Purifier must be running and operating normally in order to perform this maintenance task. Checking and adjusting operating supply and return oil pressure is for the purpose of insuring that the systems operating pressures are correctly adjusted.

For information on adjusting the inlet oil pressure refer to the section titled *Adjusting System Pressure* in the V SYSTEM START-UP AND OPERATION section of this manual

For information on adjusting the inlet oil pressure refer to the section titled *System Discharge Pressure* in the V SYSTEM START-UP AND OPERATION section of this manual

| | | |
|---|--|---|
|  |  WARNING Surfaces are HOT |  |
|  | NOTICE: Wear appropriate personal protective gear. |  |



Verify Low Oil Pressure Switch Operation

The ThermoJet Oil Purifier must be running and operating normally in order to perform this maintenance task. Verifying the operation of the low oil pressure switch is to insure that the oil heater turns OFF and is disabled when the oil pressure drops below 135 PSI (9.3 BAR).

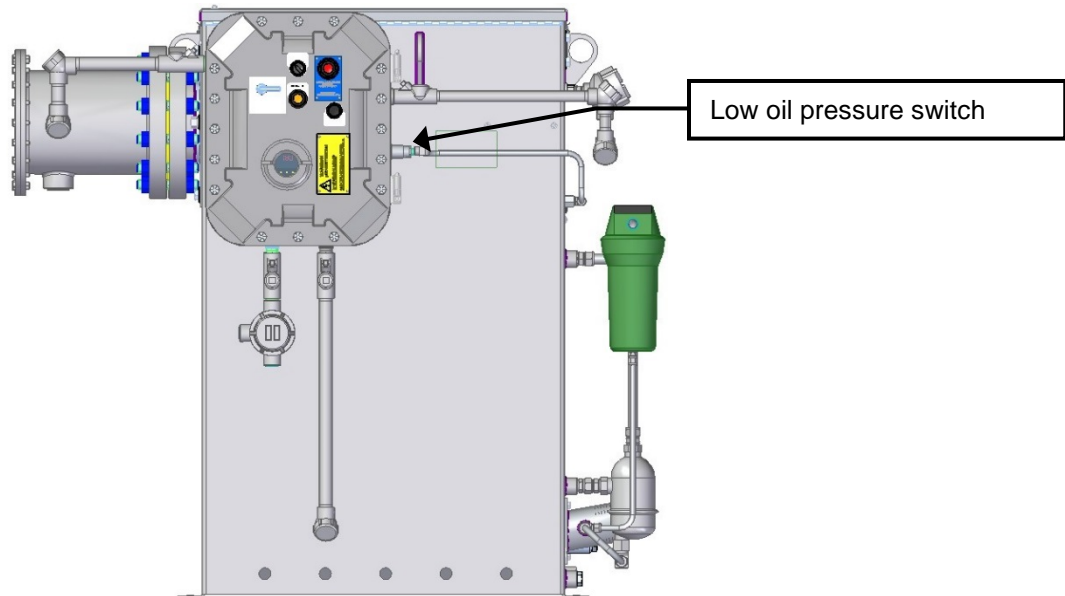
The low oil pressure switch is mounted on the right side of the electrical control enclosure. It is wired in series with the oil heater control circuit so that the oil heater is inoperable if the oil pressure drops below 135 PSI (9.3 BAR). For additional information refer to the wiring diagram included in the section of this manual titled *IX PARTS LIST / DRAWINGS / SCHEMATICS*.



| | | |
|---|----------------|---|
|  | WARNING |  |
| Surfaces are HOT | | |

| | | |
|---|--|---|
|  | NOTICE: Wear appropriate personal protective gear. |  |
|---|--|---|

While the ThermoJet is operating normally, open the top cover of the ThermoJet cabinet to access the inlet pressure control valve located on the outlet of the heater vessel. While observing the Filter Outlet Pressure gauge, loosen the lock nut and adjust the control valve by turning the adjusting screw CC-Clockwise to decrease the oil pressure. Decrease the pressure to a value that is less than the low oil pressure set point of 9.3 BAR \pm 0.3 BAR (135 PSI \pm 5 PSI).

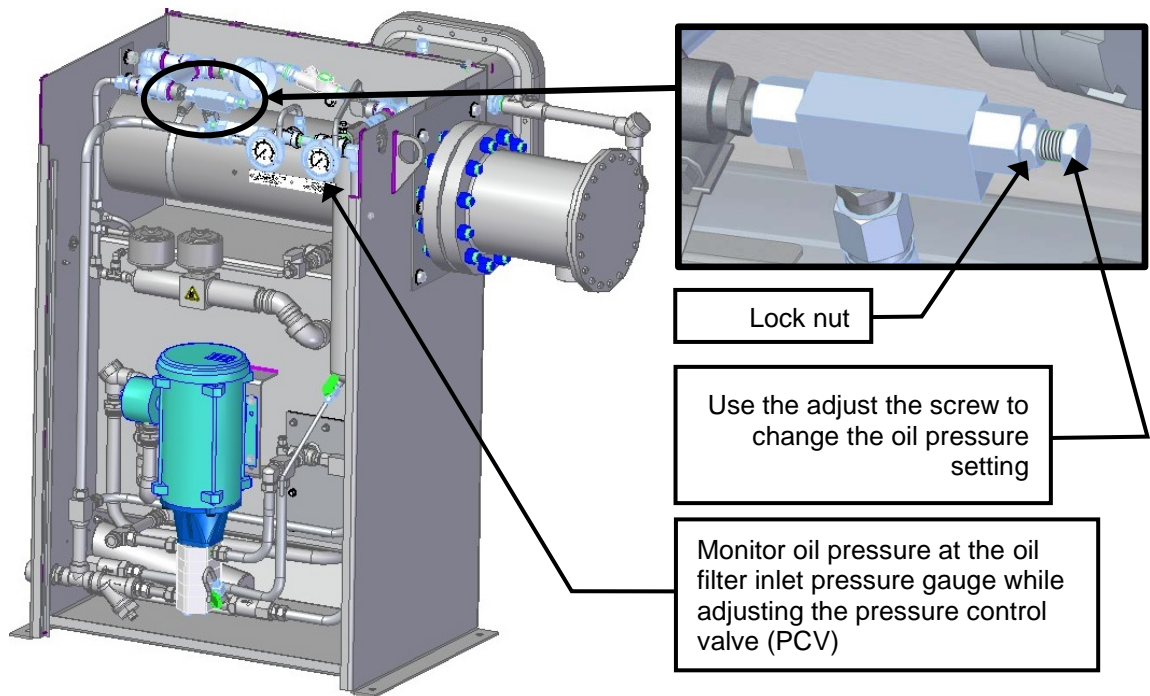

The oil heater and the oil heater ON pilot light (AMBER) will become inoperable. The oil temperature will begin to decrease. The heater and the pilot light will remain OFF as long as the oil pressure is below the low pressure set point of 9.3 BAR (135 PSI).

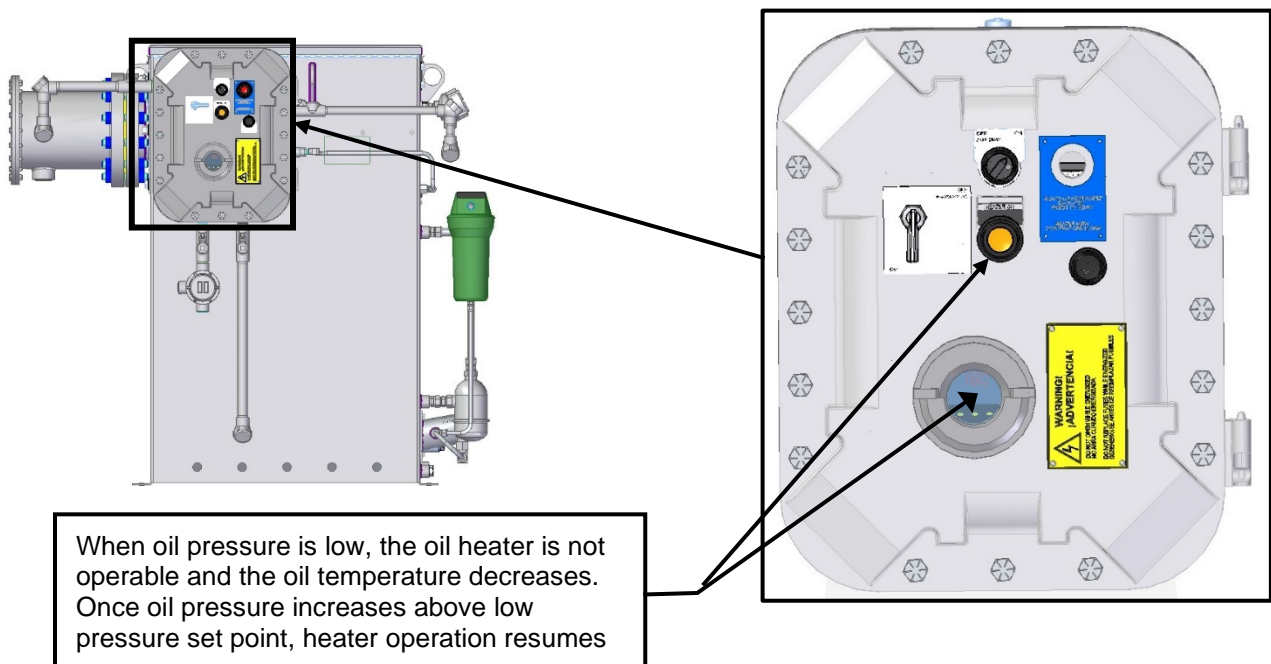

Once the low pressure switch operation has been confirmed, adjust the pressure control valve by turning the adjusting screw C-Clockwise to set the system operating pressure to it normal operating set point of 240 PSI (16.5 BAR). Securely tighten the lock nut.

Verify Oil Heater High Temperature Cutout Operation

To perform this maintenance task, the ThermoJet Oil Purifier must be running and operating normally. This maintenance task is performed to ensure safe operation should a high temperature condition occur. For additional information regarding the operation of the high temperature circuit see drawings and schematics in section of this manual titled IX PARTS LIST / DRAWINGS / SCHEMATICS.

The oil heater is equipped a thermocouples for high temperature protection. The thermocouple is clamped to the outside of the heater vessel. This thermocouple provides a signal for a high temperature alarm and cutout for the heater vessel surface.

Should the heater vessel surface thermocouple output reach the high temperature alarm/heater cutout setting, power to the oil heater element is interrupted. When this happens the oil temperature as indicated on the heater controller display will begin to decrease. As the oil temperature falls below oil heater controller setting, the heater control thermocouple will sense the decreasing oil temperature and signal the oil heater temperature controller to energize the heater. However the high limit controller will prohibit the oil heater from energizing and oil temperature will continue to fall. The Heater On pilot light will be illuminated because the heater controller is providing an ON signal to the heater power control relay.



NOTICE:

When a Heater High Temperature alarm occurs the red pilot light will illuminate. The alarm pilot light will remain illuminated and the oil heater will not be operable until the Heater High Temperature reset button is depressed. Press the reset push button to resume heater operation.

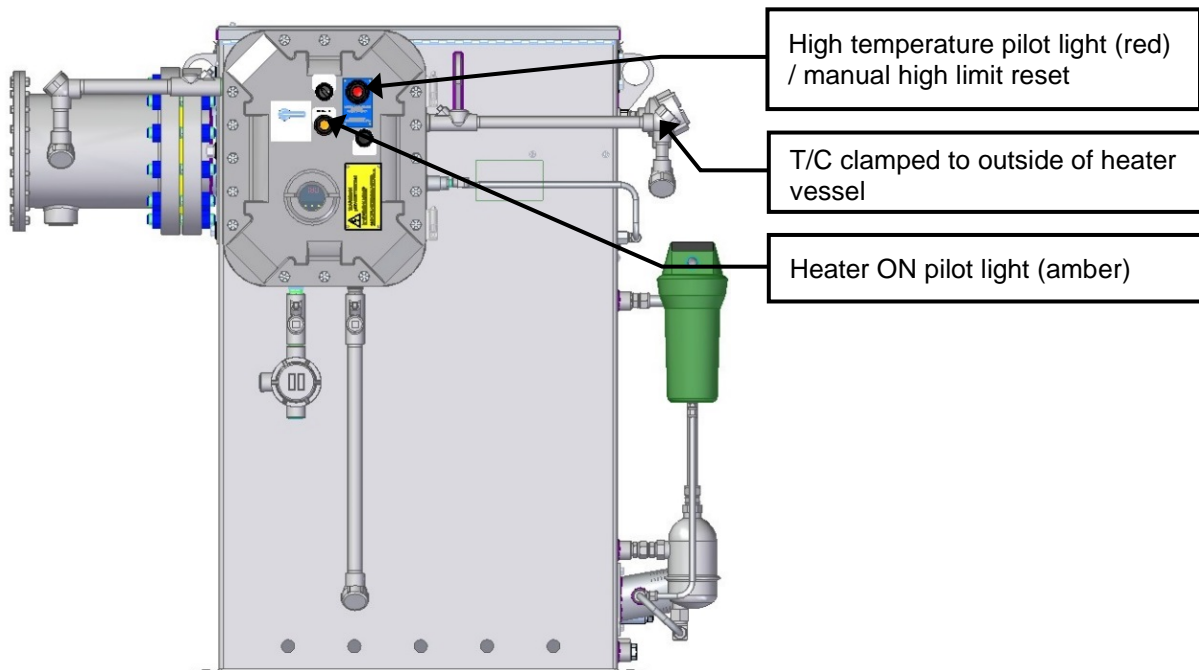

This maintenance task requires that a thermocouple simulator be connected to the terminal connectors of the thermocouple.



NOTICE:
Thermocouple simulators should be provide an output signal for a type J thermocouple up to 150°C (300°F) minimum. Devices must be approved for use in the hazardous area in which I is being used. Devices should be calibrated and labeled with the calibration date according to applicable standards.



NOTICE:
All electrical connections should only be made by a qualified electrician.

Turn the ON-OFF selector switch to the OFF position and allow the unit to shut down. Once the ThermoJet has turn OFF. Switch the disconnect switch to the OFF position.

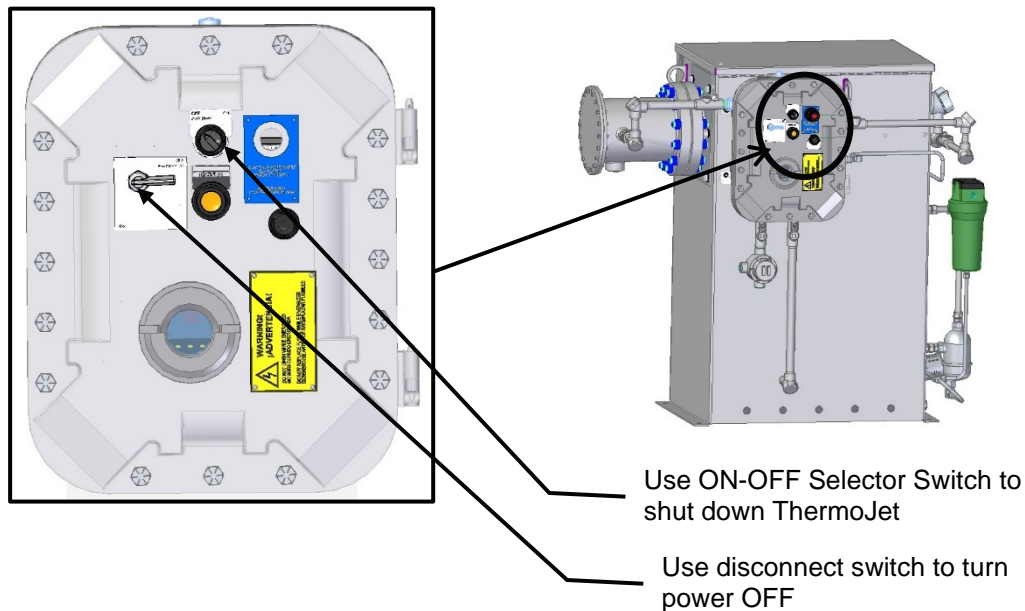

Locate the thermocouple terminal enclosure for the T/C connected to the heater vessel. Remove the terminal enclosure cover and find the terminal screws which connect the thermocouple to the high alarm circuit. Disconnect the thermocouple and wire the thermocouple simulator to the same screws. Take care to observe proper polarity for (+) and (-) terminations.

Restart the ThermoJet by turning the main disconnect to the ON position and then switching the ON-OFF selector switch to the ON position. The unit will start and oil temperature will increase to the normal operating temperature. Allow the machine to reach normal operating temperature.



NOTICE:

The Heater High Temperature alarm is set to disable the oil heater as temperature increases above $135^{\circ}\text{C} \pm 2^{\circ}\text{C}$ ($275^{\circ}\text{F} \pm 4^{\circ}\text{F}$). High temperature cutout set point is non-adjustable.

Adjust the thermocouple simulator output so that the signal replicates an increasing temperature $T < 135^{\circ}\text{C}$ (275°F) to $T > 135^{\circ}\text{C}$ (275°F). The high temperature cutout will disable the oil heater and give a local annunciation as the temperature increases above $135^{\circ}\text{C} \pm 2^{\circ}\text{C}$ ($275^{\circ}\text{F} \pm 4^{\circ}\text{F}$). Oil temperature will decrease.

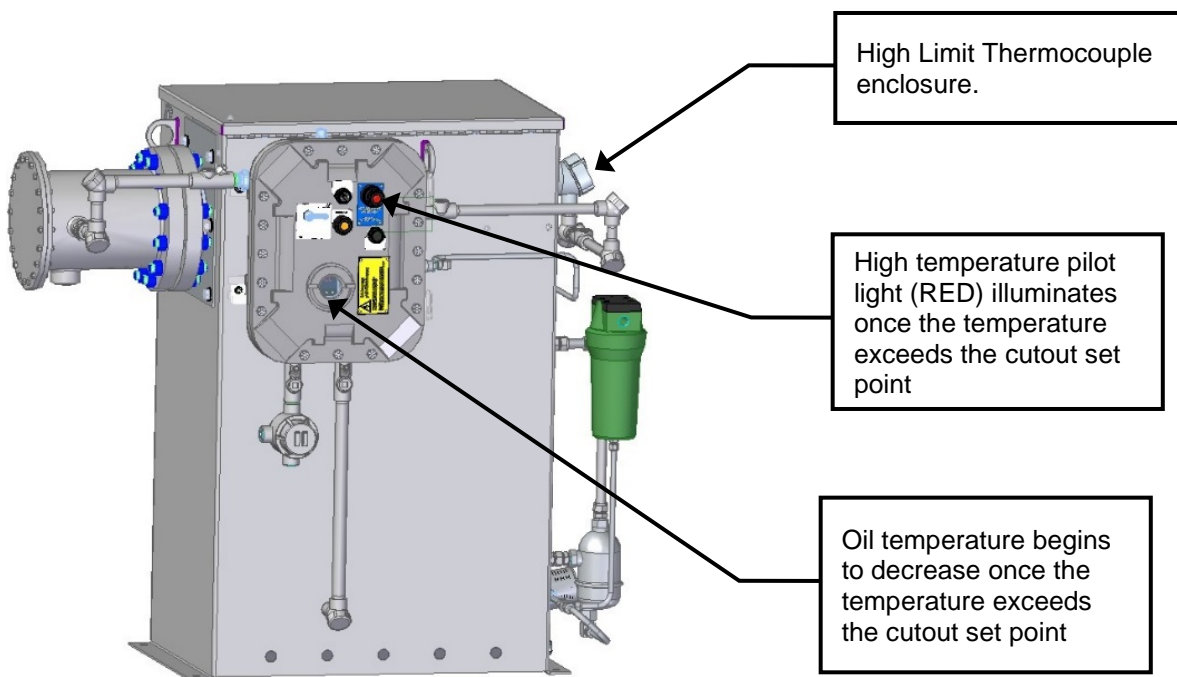

Temperature indicated on the heater controller display will begin to decrease. As the oil temperature falls below oil heater controller setting, the heater controller will sense the decreasing oil temperature and attempt to energize the heater. However the high limit controller will prohibit the oil heater from energizing and oil temperature will continue to fall. The Heater ON pilot light will be illuminated because the heater controller is providing an ON signal to the heater power control relay. For additional information refer to the wiring diagram included in the section of this manual titled *IX PARTS LIST / DRAWINGS / SCHEMATICS*.





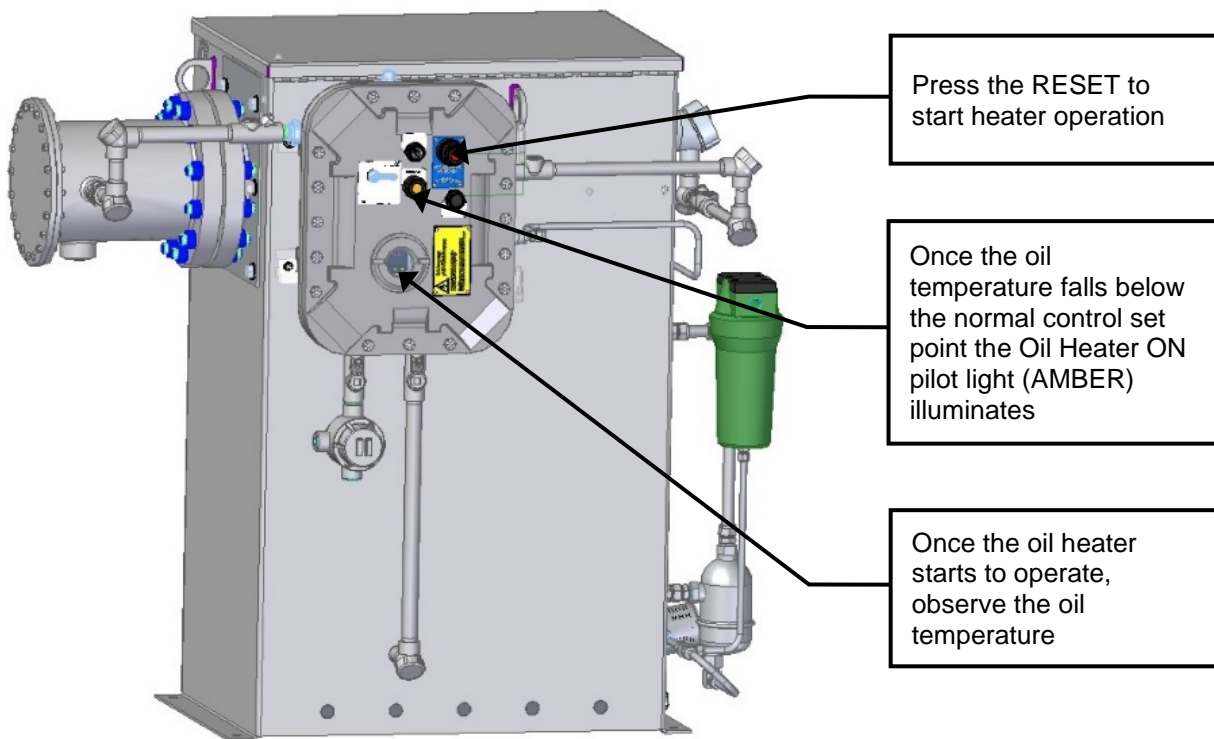

NOTICE:

When a Heater High Temperature alarm occurs the red pilot light will illuminate. The alarm pilot light will remain illuminated and the oil heater will not be operable until the Heater High Temperature reset button is depressed. Press the reset push button to resume heater operation.

Press the High Temperature Cut-Out reset button and observe the oil temperature indication on the heater temperature controller. The oil heater will resume operation and the oil temperature will increase to the normal set point.



Shut down the ThermoJet as described above. Disconnect the thermocouple simulator from the terminals and re-connect the high limit thermocouple. Take care to observe proper connections for (+) and (-) terminations. Securely re-install the enclosure covers.

| | | | | |
|--|--|--|------------------------------|-----------|
|      | THERMOJET® H-2500E SERIES OIL PURIFIER SYSTEM INSTALLATION AND OPERATING MANUAL | | Doc # | 77740119 |
| | | | Rev | 15 |
| | | | Date | June 2020 |
| | | | Page 69 of 100 | |

VII CLEANING AND DECONTAMINATION



Cleaning and Decontamination



Oil spills may be wiped up using paper, cloth or other absorbent media. Clean reservoir and cabinet surfaces with mild soap and water. If degreasing agents or solvents are used to clean oil spills, follow the label instructions of the cleaning agent. The ThermoJet Oil Purifier cabinet and reservoir are constructed from T-304 stainless steel.

Use inspecting and cleaning reservoir interiors use only lint free rags for cleaning and wiping them out.

The outside and interior of the ThermoJet Oil Purifier cabinet and reservoir may be wiped down with cloth rags or recyclable paper wipes or towels that are able to absorb oil and remove any accumulation of dust.

| | | |
|--|----------------|---|
|  | WARNING |  |
| <p>USE DAMP CLOTH ONLY TO CLEAN PLASTIC COMPONENTS. USING A DRY CLOTH TO CLEAN PLASTICS CAN GENERATE A STATIC DISCHARGE AND CREATE AN EXPLOSION HAZARD.</p> | | |

| | | |
|--|----------------|--|
|  | CAUTION |  |
| <p>In case of oil spillage, the user or other responsible body must ensure appropriate cleanup and decontamination is carried out.</p> | | |
|  | | |

| | | |
|--|----------------|---|
|  | CAUTION |  |
| <p>Ensure that decontamination or cleaning agents used do not cause a hazard as a result of a reaction with parts of the equipment. Cleaning solvents should not contact gaskets or plastic components</p> | | |
| <p>Consult with your lubricating oil supplier and the lubricating oil MSDS documentation to ensure that decontamination and cleaning agents do not react with the lubricating oil used.</p> | | |
|  | | |

**NOTICE:**

When cleaning oil spills consult with your lubricating oil supplier and the lubricating oil MSDS documentation regarding safe guards and Personal Protective Equipment (PPE) requirements

**NOTICE:**

Dispose of all contaminated cleaning materials in accordance with all environmental laws, ordinances and directives. Consult your company or plant environmental protection department for disposal policy. Understand the environmental effect any used cleaning agents used and plan your cleanup accordingly.





Use environmentally friendly products and recycle where ever possible



Direct all questions regarding the compatibility of decontamination or cleaning agents to;

Manufacturer
5615 W Fuqua St. B-201
Houston TX 77085
USA
713-464-6266

| | | | | |
|--|--|--|------------------------------|-----------|
|   | THERMOJET® H-2500E SERIES OIL PURIFIER SYSTEM INSTALLATION AND OPERATING MANUAL | | Doc # | 77740119 |
| | | | Rev | 15 |
| | | | Date | June 2020 |
| | | | Page 72 of 100 | |

Removal From Use, Disposal And Transport

When properly maintained, the ThermoJet Oil Purifier equipment is designed to provide many years of continuous service. Once the ThermoJet Oil Purifier is installed and commissioned in an operating Hydrocarbon Processing Industry (HPI) process unit, its service life can coincide with the life of the owners operation of the plant. Disposal methods used should comply with the users plant policy and guidelines used for disposal of other machinery assets.

If the ThermoJet Oil Purifier has reached the end of its useful working life and a no-repair decision is made it must be disposed through a licensed scrap or waste disposal facility. Alternately the machinery may be partially or completely striped for recycling purposes. Prior to shipment to a recycling facility or disassembly for recycling the following steps should be performed;

- All oil must be drained from the separation tank, the oil heater tube, the oil filter housing and interconnecting piping and tubing.
- Disconnect all external supply oil connections. Take care to avoid spills. For oil supply and return connection locations reference the *INSTALLATION* section of this manual.
- Remove and drain all oil supply, oil return and flare connection tubing, pipe and hardware.





In case of oil spillage, the user or other responsible body must ensure appropriate cleanup and decontamination is carried out.









- Remove all oil filters. Dispose of elements in accordance with all regulatory requirements in force at the time of equipment disposition. Consult you company environmental protection or plant safety department for guidance.





NOTICE:
Recycle all drained oils and oil filters.









- Disconnect all electrical supply wiring. For power wiring connection locations reference the *INSTALLATION* section of this manual.
- Disconnect discharge vent connection. For discharge vent connection location reference the *INSTALLATION* section of this manual

| | | |
|--|--|---|
|  |  |  |
| <p>Ensure that all previously connected sources of electrical power are disconnected before opening the AC power enclosures and attempting to disconnect electrical wiring</p> | | |

The ThermoJet Oil Purifier is secured to its foundation by anchor bolts through mounting pads around the perimeter of the cabinet. Unbolt the machine from its foundation to remove. The cabinet is equipped with lifting lugs for lifting and moving. Use appropriate lifting and transport equipment to remove this machinery.

| | | |
|---|--|---|
|  |  |  |
| <p>Do not tip or stand equipment on edge</p> | | |

| | | |
|--|--|---|
|  |  |  |
| <p>Use suitable transport equipment for lifting and setting the equipment into place. Ensure that the equipment is secured prior to and during lifting and transport. Stand clear of the all equipment while being maneuvered. Crane and fork truck operators should be properly trained in there operation.</p> | | |
| | |  |

| | | |
|---|--|---|
|  | <p>NOTICE: Equipment is fitted with lifting lugs. For safe lifting and placement of equipment use approved lifting cables and accessories</p> |  |
|---|--|---|

| | | | | |
|---|--|--|------------------------------|-----------|
|  | THERMOJET® H-2500E SERIES OIL PURIFIER SYSTEM INSTALLATION AND OPERATING MANUAL | | Doc # | 77740119 |
| | | | Rev | 15 |
| | | | Date | June 2020 |
| | | | Page 74 of 100 | |

Draining and Cleaning Procedures

Draining and cleaning procedures must be practiced if the ThermoJet is being used to remove water contaminant in different type of oil and from different reservoirs. The following procedures are listed in order of criticality. Depending upon any variety of individual situations, they may be either followed to conclusion, modified as desired, or discontinued at any point.

1. Shut off the reservoir drain valve; energize the motor so that the major portion of oil in the system can be pumped out within a few minutes. Piping must have an atmospheric vent in order for air to enter the piping system. If the suction and the discharge hoses were attached to the portable unit, care must be taken to ensure that oil in these lines are pumped out.



NOTICE:

This procedure allows the pumps to run “dry”, but it will not damage them since they are lubricated with the residual oil. However, this procedure should not continue for more than a few minutes because the pump requires inlet oil to lubricate and cool the gears of the pump, and the operator should be in attendance to monitor it while draining the equipment.

2. Remove the drain cap from the separation vessel and drain the oil into a suitable container.
3. To drain the oil from the filter housing, remove the air vent screw located on the top of the filter housing to prevent siphoning of oil out of the heater tube. Then open the drain valve at the bottom of the filter housing and allow the oil to drain into a suitable container.
4. To drain the heater vessel, open the drain valve and drain the oil into a suitable container.



NOTICE:





For many situations the above procedures are adequate for removing most of the oil from the system in order to prepare the ThermoJet for use on similar or compatible oil..

5. Remove the oil filter element and install a new one.
6. Remove the screen from the Y-strainer and clean it.
7. If preparing the unit for use on a significantly different type of oil, perform one or all of the following procedures:
 - Connect the ThermoJet to a small supply of the next oil to be purified (minimum 20 gallons), and circulate the fresh oil to flush out the existing oil for a minimum of 15 minutes, or up to 60 minutes if the ThermoJet is especially dirty.
 - Connect the system to a supply of compatible solvent (or other cleaning agent) and circulate to flush for a minimum of 15 minutes.



Do not use flammable cleaning solvents to flush this system. Failure to do so may result in serious injury or even death.



| | | | | |
|--|--|--|------------------------------|-----------|
|      | THERMOJET® H-2500E SERIES OIL PURIFIER SYSTEM INSTALLATION AND OPERATING MANUAL | | Doc # | 77740119 |
| | | | Rev | 15 |
| | | | Date | June 2020 |
| | | | Page 75 of 100 | |

VIII TROUBLE SHOOTING

Trouble Shooting Guide

The following information is designed for identifying potential problems and possible solutions on the ThermoJet Oil Purifier. For complete operating instructions, parts list, electrical schematics and component locations refer to other sections of this manual

| PROBLEM | SOLUTION |
|-------------------------------|---|
| No Flow in the Suction Line | <ul style="list-style-type: none"> A. Verify motor rotation is in the proper direction. B. Verify that any valves between the oil supply tank and the system inlet are open. C. Verify that there are no inlet line blockages other than closed valves. D. Check and clean inlet Y-strainer. E. Check that hoses are fully extended without kinks, or if hard-piped, that there are no elevated sections to create air pockets. F. Verify that inlet line sizes are as specified in Section III of this manual. G. Verify that suction lift does not exceed 8 feet (2.4 meters). H. Verify that oil viscosity does not exceed 3,000 SSU. I. If the pump is noisy, check for damage, wear, foreign objects, relief valve set too low or stuck open. <p>NOTE: The pump may be noisy upon cold start-up and while air is being bled from the suction line, but will quiet down once it achieves normal operating temperature</p> |
| No Flow in the Discharge Line | <ul style="list-style-type: none"> A. Ensure that there are no valves or other line-blocking devices or debris in the discharge line. If there are, remove them. B. Verify that the inlet pump flow into the separation tank is sufficient to supply the outlet pump. C. If the pump is noisy, check for damage, wear, foreign objects, relief valve set too low or stuck open. |
| No Vapor Discharge | <ul style="list-style-type: none"> A. Verify that no line-blocking devices are installed in the vent connection or in the drain line. B. Check the oil condition. If there is little or no water present, no vapor or condensate will exhaust through the vent connection. |

Temperature
Control
Problems

Low Oil Temperature

- A. Verify that the “heater on” light is illuminated.
- B. Verify the unit is connected to the correct power supply.
- C. Verify that the temperature controller is set at the desired operating temperature. If the temperature controller is set to the desired temperature, then the parameters of the PID temperature controller may have drifted and need to be readjusted. To adjust the parameters of the temperature controller, initiate the auto-tune function of the controller. To initiate the auto-tune function, depress the up arrow and the down arrow keys of the controller at the same time for longer than 4 seconds. After the up key and the down key are released, the process value should start flashing. This flashing indicates that the auto-tune function of the temperature controller has been started. Once the controller enters auto-tune mode, the ThermoJet® must be running so that the controller can learn the process which the ThermoJet® is operating. The flashing should last for several minutes but the length of time will vary per application. Once the flashing stops, the temperature controller should have adjusted the temperature values and the temperature should return to normal level.
- D. Verify that the temperature the controller is reading from the thermocouple is accurate. A method of accomplishing this might be to remove the thermocouple that is in the ThermoJet® and attempt to read ambient condition or a known temperature. Then verify that the temperature reading being displayed by the temperature controller would match the temperature of the ambient or known condition. If the two temperatures do not match, then either the temperature controller or the thermocouple may need to be replaced.
- E. If all of the above are correct, then check the heater resistance, the heater contactor, the temperature controller contactor, and the pressure switch for possible malfunction.

High Oil Temperature

- A. Verify that oil is flowing normally and the inlet pressures to the oil filter are normal.
- B. Verify that the temperature controller is set at the desired operating temperature. The parameters of the PID temperature controller may have drifted and need to be readjusted. To adjust the parameters of the temperature controller, initiate the auto-tune function of the controller. To initiate the auto-tune function, depress the up arrow and the down arrow keys at the same time for longer than 4 seconds. After the up key and the down key are released, the process value should start flashing. This flashing indicates that the auto-tune function of the temperature controller has been started. The flashing should last for several minutes but the length of time will vary per application. Once the flashing stops, the temperature controller should have adjusted the temperature values and the temperature should return to a normal level.
- C. Verify that the heater contactor is neither stuck, nor has failed in the energized position. If so, replace the contactor.

| | |
|-------------------------------------|---|
| Excessive noise/vibration | <p>A. Check that all inlet line connections are tight and properly sealed.</p> <p>B. Ensure that the suction connection in the reservoir is not adjacent to or near to any oil return connection which could cause oil foaming.</p> <p>C. With a ¾" wrench, exercise the inlet and outlet pressure control valves. There may be a piece of trash stuck in one of these valves that is causing the valve to chatter. After exercising the valves and the trash has been removed, reset the valve to its previous position by ensuring that all the operating pressures are back to the normal values. Exercising these two valves will change the pressure in which the unit is running.</p> |
| High/ low filter discharge pressure | <p>If filter discharge pressure range is too high, replace filter element. <i>(Replace filter element at maximum 30 PSIG (2 bar) differential)</i></p> <p>If filter discharge pressure range is too low with a clean filter, reset pressure relief safety valve (PRV1) by turning off machine for 15 seconds and allow the pop-off valve to reseat. Restart the machine and check pressure settings. Adjust PCV1 if necessary.</p> |
| Outlet Pressure | <p>The normal outlet pump discharge pressure range should be 3.4-608 BAR (50-100 PSIG).</p> <p>If outlet pump discharge pressure range is too high, check the return line for blockage.</p> <p>If outlet pump discharge pressure range is too low, reset PRV2 by turning off machine for 15 seconds and allow the pop-off valve to reseat. Restart the machine and check pressure settings.</p> |



NOTICE:

DO NOT adjust pressure setting in PRV1 & PRV2. Relief valves are they are factory set at 290 PSIG.



WARNING



In no case should the pressure be allowed to exceed 300 PSIG. If such a high pressure is indicated, immediately turn off the unit, and take any necessary steps to pre-heat the oil. Refer to shut down procedures. If this occurs use the main shut off switch. This unit is equipped with a two- (2) minute time delay for cooling down the oil heater during a normal shutdown.

| | | | |
|---|--|------------------------------|-----------|
|  | THERMOJET® H-2500E SERIES OIL PURIFIER SYSTEM INSTALLATION AND OPERATING MANUAL | Doc # | 77740119 |
| | | Rev | 15 |
| | | Date | June 2020 |
| | | Page 79 of 100 | |

Quick Reference Troubleshooting Guide

| DO | DON'T |
|---|---|
| Drain free water from the bottom of reservoir | Operate with inadequate oil flow caused by suction line too small, elevated sections of suction piping, excessively high viscosity, excessive suction lift or suction line restrictions |
| Install oil filter element | |
| Change oil filter element at 30 PSID | Operate with excessive solids contamination. The oil filter element within the ThermoJet is not designed to clean up the solid particulate in oil reservoirs. The element is designed to protect critical systems within the ThermoJet and will load up with particulate very quickly and requires frequent changes if a pre-filter package is not used. Contact customer service for technical assistance if frequent filter loading occurs. |
| Clean Y-strainer screen | Attempt to remove contaminants not designed for air stripping such as heavy hydrocarbons, ethylene glycol, carbon black, or motor oil contaminants |
| Compound gauge reading zero BAR (0 PSIG) | Operate with contaminants which attack Viton seals |
| Operate at recommended pressures and temperature | Connect to a pressurized reservoir without inlet pressure-reducing valve or discharge boosting means |
| Return oil above reservoir level | Expect satisfactory performance when rate of contaminant intrusion exceeds removal rate |
| Vent line extends at least fifteen (15) feet vertically above the ThermoJet | Adjust factory set 290 PSIG (20 BAR) pop-off relief valve |
| Operate at correct voltage and frequency | Reduce the inner diameter of the suction and discharge lines. |
| Ensure power supply breakers or fuses are adequately sized for the full load amps | |
| Operate motor clockwise facing the fan | |
| Change oil absorption media sock | |

| | | | | |
|---|--|--|------------------------------|-----------|
|  | THERMOJET® H-2500E SERIES OIL PURIFIER SYSTEM INSTALLATION AND OPERATING MANUAL | | Doc # | 77740119 |
| | | | Rev | 15 |
| | | | Date | June 2020 |
| | | | Page 80 of 100 | |

Types of Product Misapplication and Misuse Not Covered By Warranty or Guarantees

1. Prolonged operation with air bubbles in the oil flow which causes pump cavitation and/or relief valve chatter.
2. Excessive water ingress beyond the system capability at maximum operating temperature.





NOTICE:





If this is a temporary condition, free water may be drained manually from the reservoir while a permanent solution is implemented. If it is constant condition, request customer service on the feasibility of installing an automatic water drain valve.

3. Operating with inadequate oil flow caused by:
 - A. Suction lines too small.
 - B. Elevated sections of suction piping.
 - C. Suction line restrictions.
 - D. Excessively high viscosity.
 - E. Excessive suction lift.
4. Excessive solids contamination with no pre-filter.
5. Presence of contaminants which are not within the scope of removal for air stripping technology, for example heavy hydrocarbons, ethylene glycol, carbon black or attempting to purify motor oils.
6. Presence of contaminants which attack Viton seals.
7. High differential pressure on oil filter.
8. Operating without oil filter element or inlet Y-strainer element.
9. Operating with inlet Y-strainer plugged.
10. Incoming oil temperature too cold for heater capacity (except for small reservoir volumes).
11. Operating either above or below recommended operating pressures.
12. Discharging oil into reservoir below the oil level.
13. Operating on under-voltage, over-voltage or wrong voltage.
14. Inadequate power supply, i.e. amperage rating of breaker or fuses under-sized for load required.
15. Vent line piping not extending fifteen (15) feet above the **ThermoJet®**.
16. Connection to pressurized reservoir without inlet pressure reducing valve or discharge boosting means

IX PARTS LIST / DRAWINGS / SCHEMATICS

| | | |
|--|--|--|
|  |  <p>EXPLOSION HAZARD – Substitution of components may impair suitability for Class 1 Groups CD</p> |  |
|--|--|--|

| | |
|---|---|
|  | <p>NOTICE: All electrical checks and circuit testing should only be made by a qualified electrician.</p> |
|---|---|

| | | |
|---|---|--|
|  |  <p>Before removing the cover to the controller contact appropriate operating personnel and obtain all required hot work permits. Ensure that the area has been inspected and determined to be nonhazardous. Observe all hot work permit procedures and policies.</p> |   |
|---|---|--|



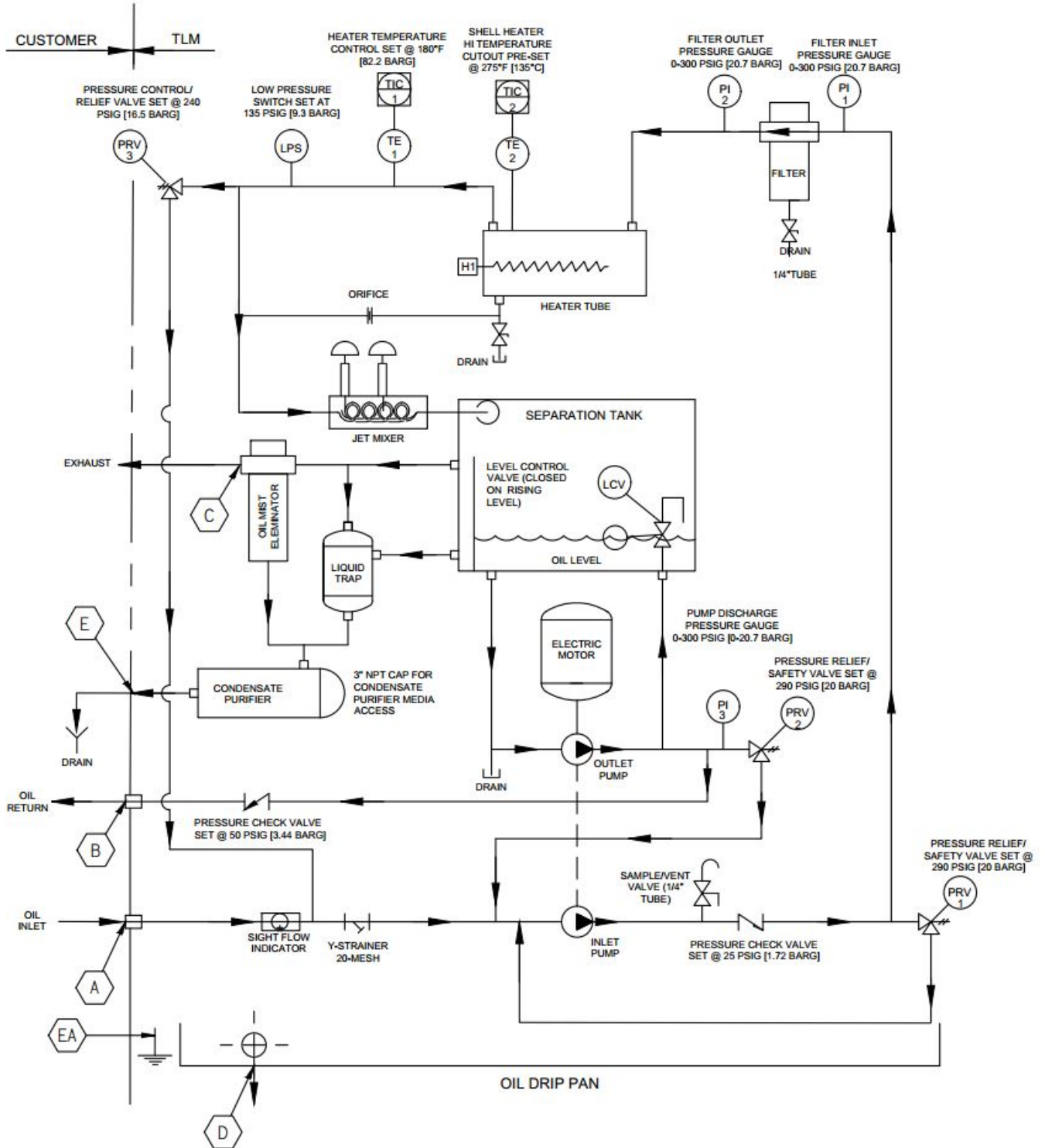

Maintenance Spare Parts List

| <u>Part Number</u> | <u>Description</u> | <u>Quantity</u> |
|--------------------|-------------------------------------|-----------------|
| 1910-3006 | Oil Filter Element 6 Microns | 1 |
| 4052-0235 | Filter Housing O-Ring, Viton | 1 |
| 1920-1002 | Oil Absorption Media Sock | 1 |
| 77750101 | Filter Element, Demisting 1 Microns | 1 |

Process and Instrument Diagram

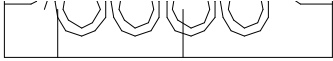

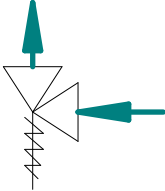
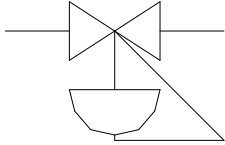
PID Symbol Legend and Customer Connection Chart

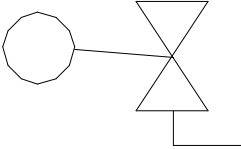
| | |
|--|--|
|  | |
|  | |
|  | |
|  | |
|  | |
|  | |
| | |
| | |

Electrical Wiring Diagram

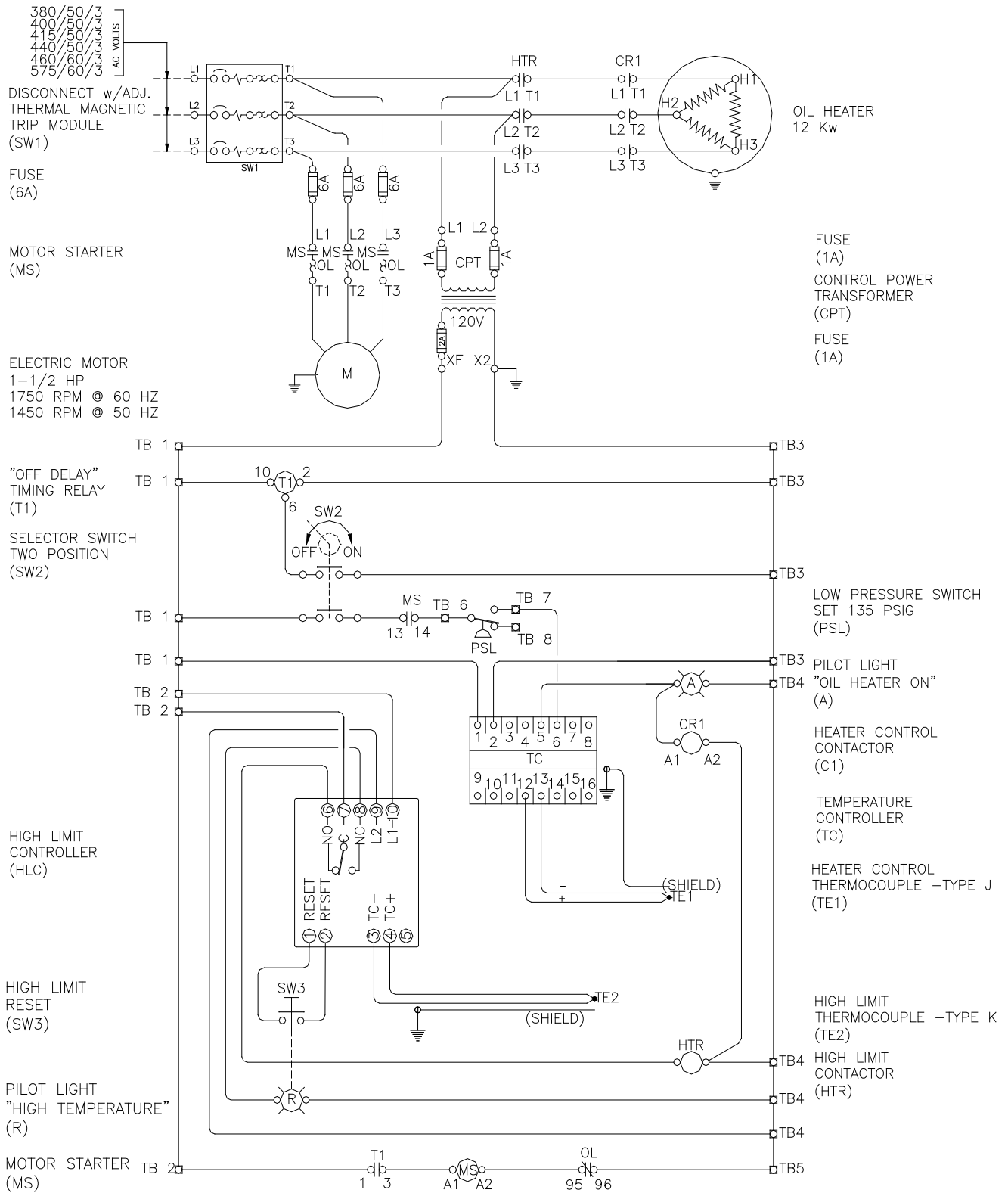

Transformer Wiring

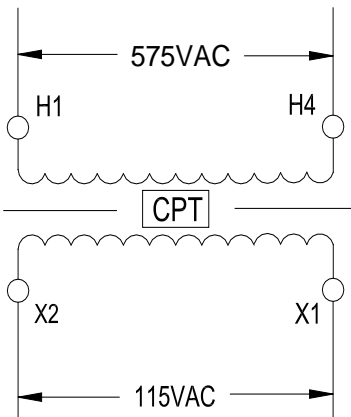
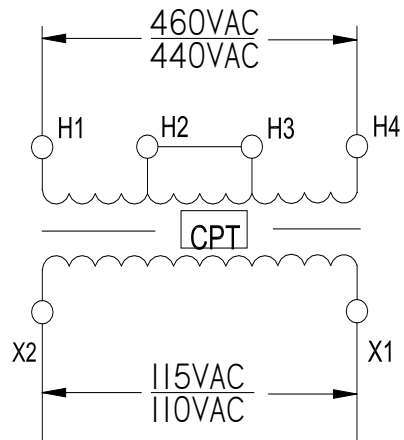
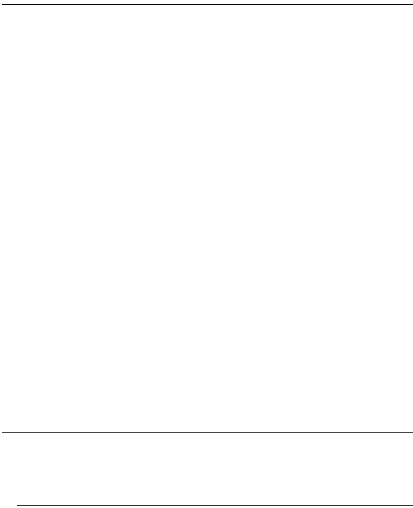

Fuse Ratings and Characteristics

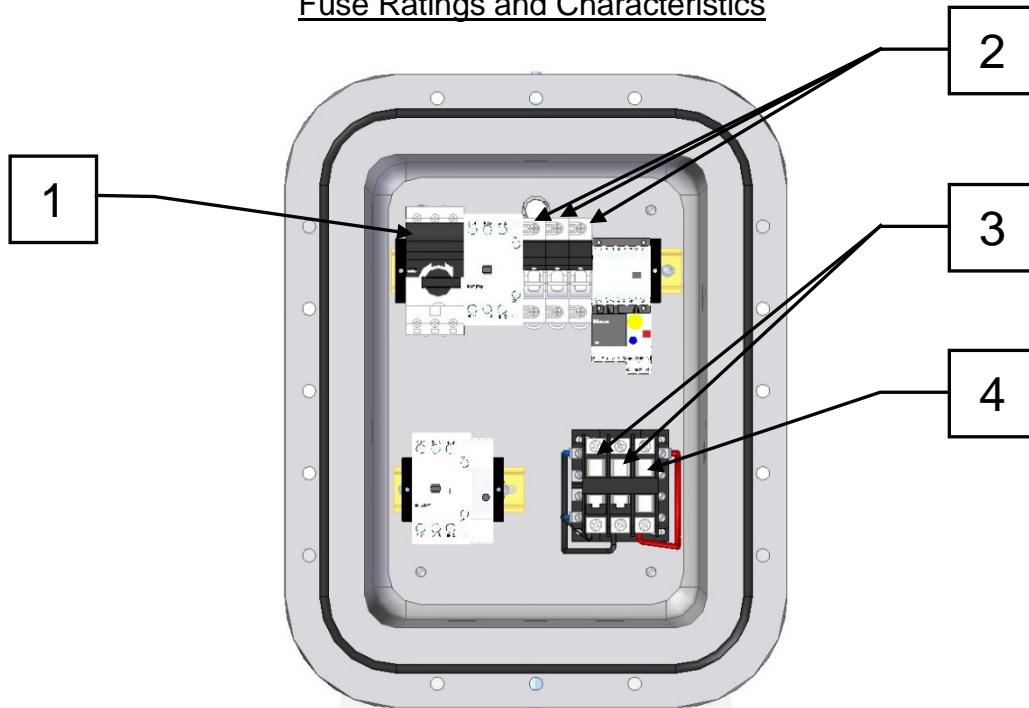

| Item | Part Number | Quan | Description |
|------|----------------|------|---|
| 1 | 30571032 | 1 | TRIP BLOCK, 8-32 AMPS |
| 2 | 77750215 <R13> | 3 | Time Delay Fuse, Class CC - 600V - 6 Amp |
| 3 | 30180010 | 2 | Time Delay Fuse, Class CC - 600V - 1 Amp |
| 4 | 30180021 | 1 | Time Delay Fuse, 13i32 X 1-1i2 _ 250V - 2 Amp |

WARNING

ENSURE THAT ELECTRICAL POWER IS TURNED OFF PRIOR TO OPENING ENCLOSURE AND REPLACING FUSES.

| | | | |
|---|--|------------------------------|-----------|
|  | THERMOJET® H-2500E SERIES OIL PURIFIER SYSTEM INSTALLATION AND OPERATING MANUAL | Doc # | 77740119 |
| | | Rev | 15 |
| | | Date | June 2020 |
| | | Page 88 of 100 | |

Bill Of Materials

| Item | Part Number | Quan | Description |
|------|-------------|---------|--|
| 1 | 02500001 | 1 | Double Spur gear Pump |
| 2 | 03501000 | 1 | Jet Mixer |
| 3 | 15000300 | 3 | Pressure Gauge, 0-300 PSI |
| 4 | 19103006 | 1 | Filter Element, 6 Micron |
| 5 | 19201002 | 1 | Oil Absorption Sock Media |
| 6 | 19701001 | 1 | Oil Filter Housing, ¾ NPT, SS |
| 7 | 30100601 | 1 | Transformer, Control, 440/460/480 VAC//110/115/120 VAC - 100VA, w Fuse Blocks (note 4) |
| | 30100603 | | Transformer, Control, 380/400/415 VAC//115/230 VAC - 100VA, w Fuse Blocks (note 1, 2, 3, 5) |
| | 30100605 | | Transformer, Control, 575 VAC//120 VAC - 100VA_w Fuse Blocks (note 6) |
| 8 | 30110120 | 1 | Contactora, Motor Starter - 3 Pole w AC Coil, 110/120 VAC, 50/60 Hz |
| 9 | 30140024 | 1 | Overload Relay, For Three Phase Motor, 1.6 - 2.4 Amp, Direct Mount (note 6) |
| | 30140040 | | Overload Relay, For Three Phase Motor, 2.4 - 4 Amp, Direct Mount (note 1, 2, 3, 4, 5) |
| 10 | 30180010 | 2 | Time Delay Fuse, Class CC - 600V - 1 Amp |
| 11 | 77750215 | <R13> 3 | Time Delay Fuse, Class CC - 600V - 6 Amp |
| 12 | 30180021 | 1 | Time Delay Fuse, 13i32 X 1-1i2 _ 250V - 2 Amp |
| 13 | 30201014 | 1 | Ground Lug |
| 14 | 30571000 | 1 | Basic Switching Device |
| 15 | 30600102 | 1 | Temperature Controller, Input voltage 90-264VAC - 50/60HZ, Output Relay 3A/240VAC, ,Fahrenheit Readout |
| 16 | 30600200 | 1 | High Limit Control w Man Reset - Non Potted w Sc Term, Type J TC, Set 180 C / 356 F |
| 17 | 33000100 | 1 | Float, SS 6 Inch Diameter |
| 18 | 36001380 | 1 | Oil Heater, 380V, 3Ph, 12 Kw, 6" 300# ANSI Flange EXP Housing(note 1) |
| | 36001400 | | Oil Heater, 400V, 3Ph, 12 Kw, 6" 300# ANSI Flange EXP Housing (note 2) |
| | 36001415 | | Oil Heater, 415V, 3Ph, 12 Kw, 6" 300# ANSI Flange EXP Housing (note 3) |
| | 36001440 | | Oil Heater, 440V, 3Ph, 12 Kw, 6" 300# ANSI Flange EXP Housing (note 4) |
| | 36001460 | | Oil Heater, 460V, 3Ph, 12 Kw, 6" 300# ANSI Flange EXP Housing (note 5) |
| | 36001215 | | Oil Heater, 575V, 3Ph, 12 Kw, 6" 300# ANSI Flange EXP Housing (note 6) |
| 19 | 36101001 | 1 | Heater Insulation Blanket |
| 20 | 77760518 | <R13> 2 | Power Relay / Motor Starter, 3 Pole – 32 Amp, 110v 50 Hz , 120v 60 Hz Coil, W/ N.O. Aux Contact |
| 21 | 40500060 | 1 | Gasket, Flexitalic 6 inch, 300# RF |
| 22 | 40511031 | 1 | Gasket, Oil Level Control Plate - VITON |



**THERMOJET® H-2500E SERIES
OIL PURIFIER SYSTEM
INSTALLATION AND OPERATING MANUAL**

| | |
|------------------------------|-----------|
| Doc # | 77740119 |
| Rev | 15 |
| Date | June 2020 |
| Page 89 of 100 | |

| Item | Part Number | Quan | Description |
|------|--------------------------|------|---|
| 23 | 40520235 | 1 | O-ring, Oil Filter - VITON |
| 24 | | | Item Not Used |
| 25 | 49002075 | 1 | Y-Strainer |
| 26 | 50000010 | 1 | Water Condensate Trap |
| 27 | 51001137 | 1 | Back Pressure Control - Pressure Limiting Valve, Direct Acting, 3i8 NPT, SS Body |
| 28 | 51055050 <R13> | 1 | Plug Valve, ½ NPT SS |
| 29 | 51052525 | 1 | Plug Valve, ¼ NPT SS |
| 30 | 51850100 | 1 | Valve, Level Control |
| 31 | 52500075 | 1 | Check Valve, 25 PSI (1.7 BAR) |
| 32 | 52002075 | 1 | Check Valve, 50 PSI (3.4 BAR) |
| 33 | 77750106 | 1 | Thermocouple, 1/4 X 3, Type J, ½ x ½ NPT Coupling, EXP Mounting Head |
| 34 | 77760524 | 1 | Thermocouple, 1/4 X 7, Type J, ½ x ½ NPT Coupling, EXP Mounting Head |
| 35 | 51001237 | 2 | Safety Relief Valve, 3/8 X 3/8 NPT, SS, Set 290 PSI |
| 36 | 02100001 | 1 | Pump Motor Mount, USA4F17 Pump to NEMA 143TC Flanged Motor |
| 37 | 77780966 35510404 | 1 | MOTOR, ELECTRIC 1-1/2HP NEMA 7, 145TC; EXP Proof, 1-1/2 HP 1-1/2 HP 230/460VAC 60HZ 1750RPM; 190-220/380-440VAC 3 PHASE 50HZ 1400 RPM (note 1, 2, 3, 4, 5) MOTOR, ELECTRIC 1-1/2HP NEMA 7, 145TC, 1-1/2 HP 575VAC 3 PHASE 60HZ; 1750RPM (note 6) |
| 38 | 77780680 | 3 | Fuse Holder, Class CC Type Fuse, DIN Rail Mount, Single Pole, 30 Amp |
| 39 | 77780929 | 1 | Pressure Switch, Adjustable 40-200 PSI (2.8-3.8 BAR), , Set 135 PSI (9.33 BAR) Dec |
| 40 | 77781040 | 1 | Timing Relay, OFF Delay, 60-600 Sec - DIN Rail Mount |
| 41 | 19000125 | 1 | Air Breather – 1-1/4 NPT |
| 42 | 19000050 | 1 | Air Breather – 1/2 NPT |
| 43 | 77750102 | 1 | Demisting Filter |
| 44 | 77781259 | 1 | Two Position Selector Switch Assembly, DPDT |
| 45 | 77781258 | 1 | Press to Test Pilot Light_CL1 GRP BCD, Red Lens, 120 VAC |
| 46 | 77781257 | 1 | Pilot Light_CL1 GRP BCD, Amber Lens, 120 VAC |

Note:

- 1) Used in Model H2500-EE** - 380Volt – 50 Hz Electrical Power Supply
- 2) Used in Model H2500-EC** - 400Volt – 50 Hz Electrical Power Supply
- 3) Used in Model H2500-EK** - 415Volt – 50 Hz Electrical Power Supply
- 4) Used in Model H2500-MC** - 440Volt – 50 Hz Electrical Power Supply
- 5) Used in Model H2500-EA** - 460Volt – 60 Hz Electrical Power Supply
- 6) Used in Model H2500-ED** - 575Volt – 60 Hz Electrical Power Supply

General Arrangement Drawings

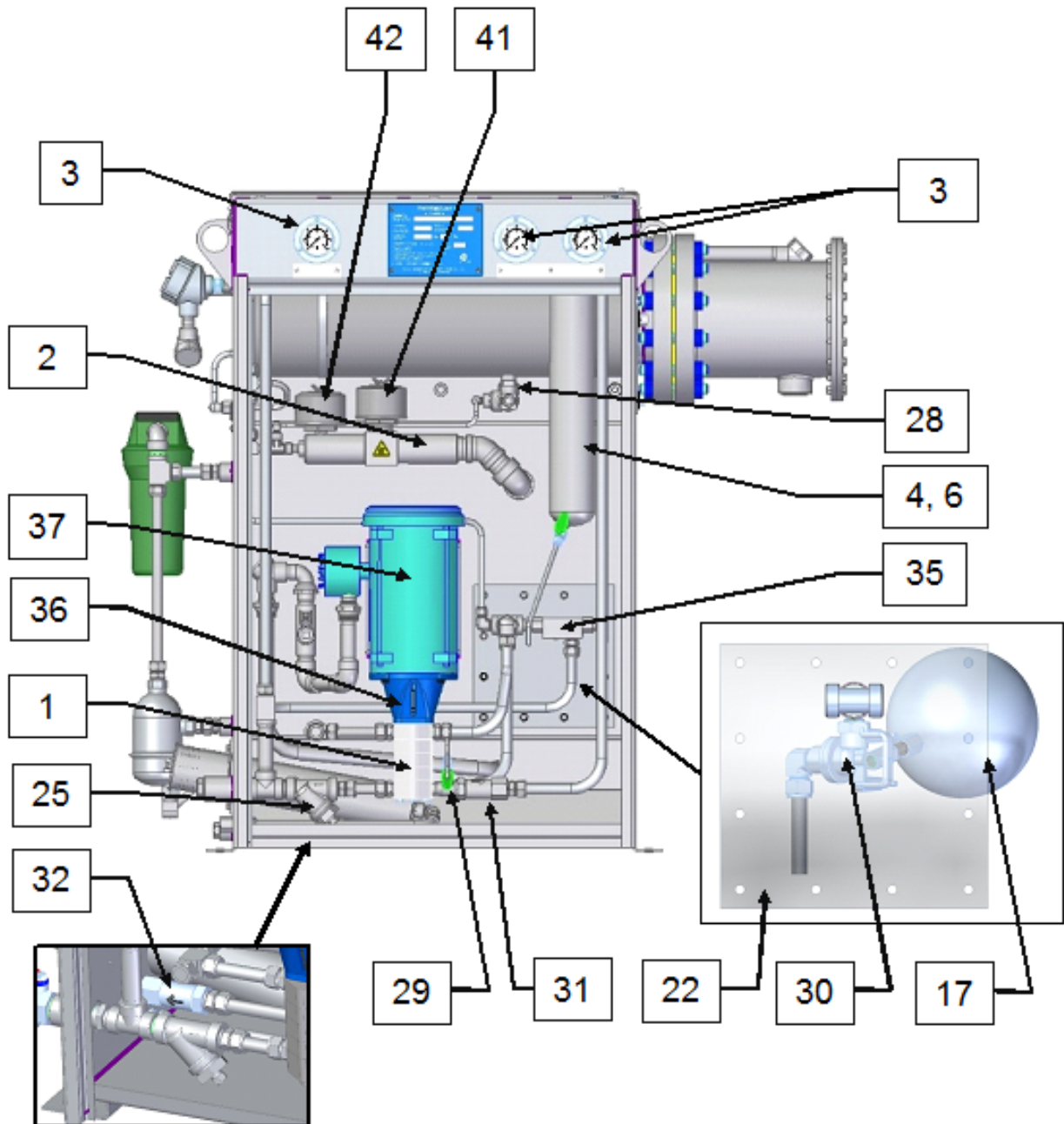

Front View w/ Door Opened

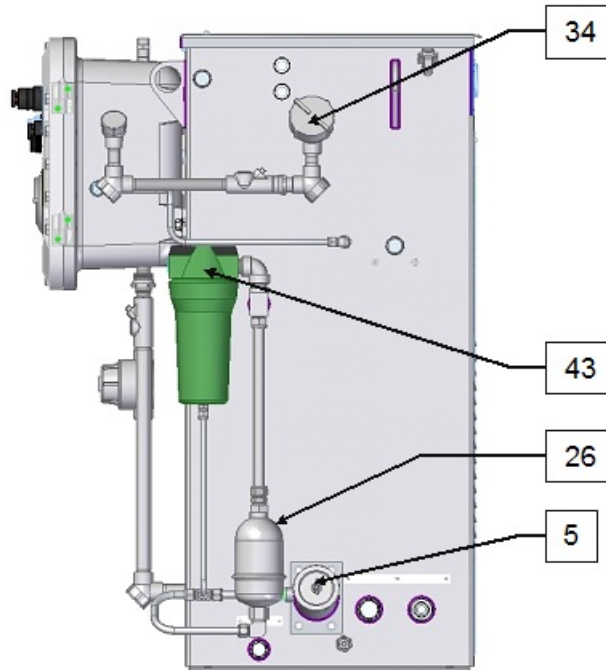

Left Side View

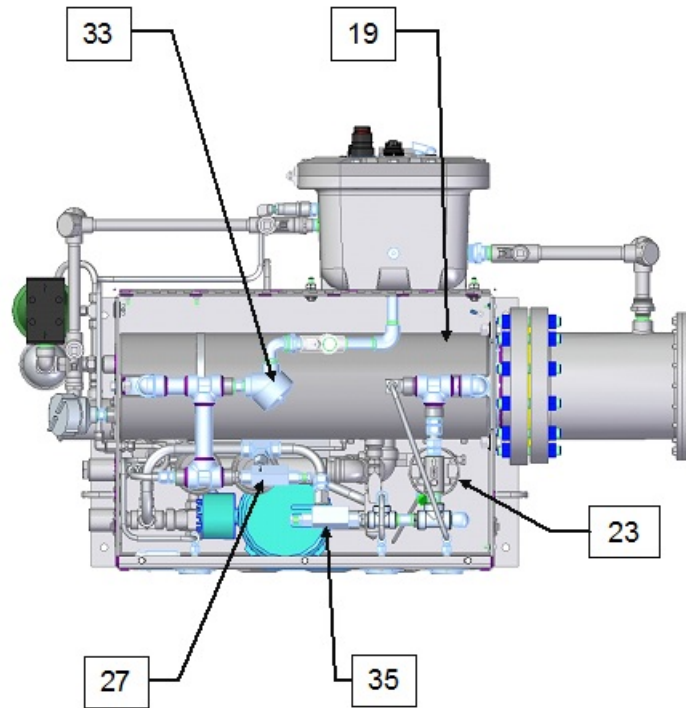

Top View

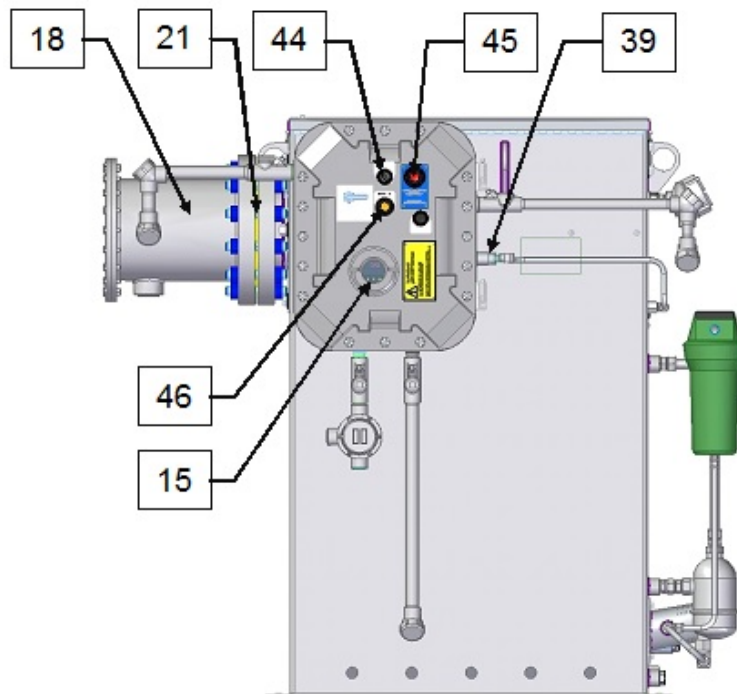

Rear View

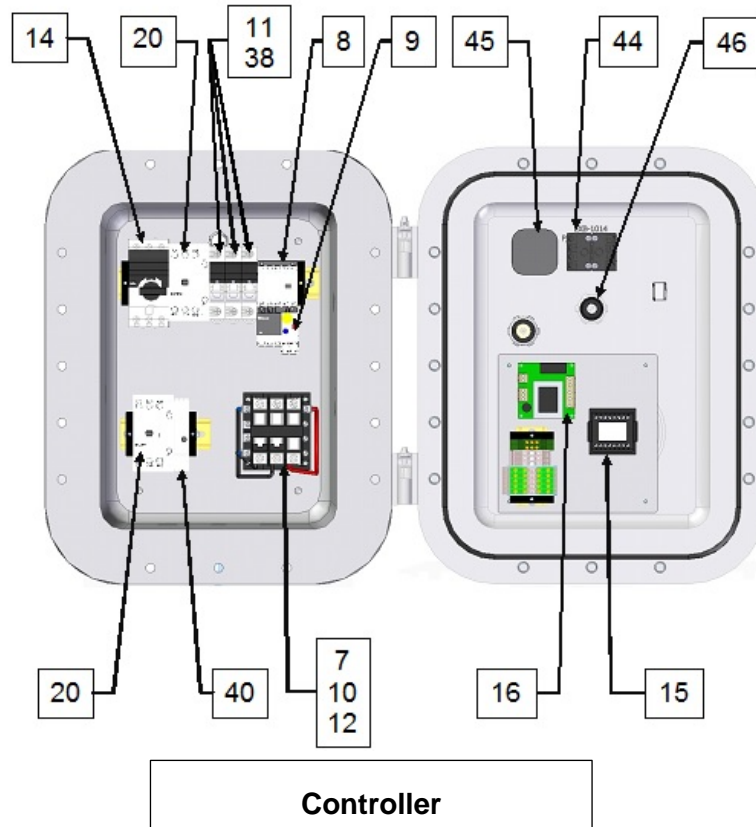

Dimensional Outline Drawings

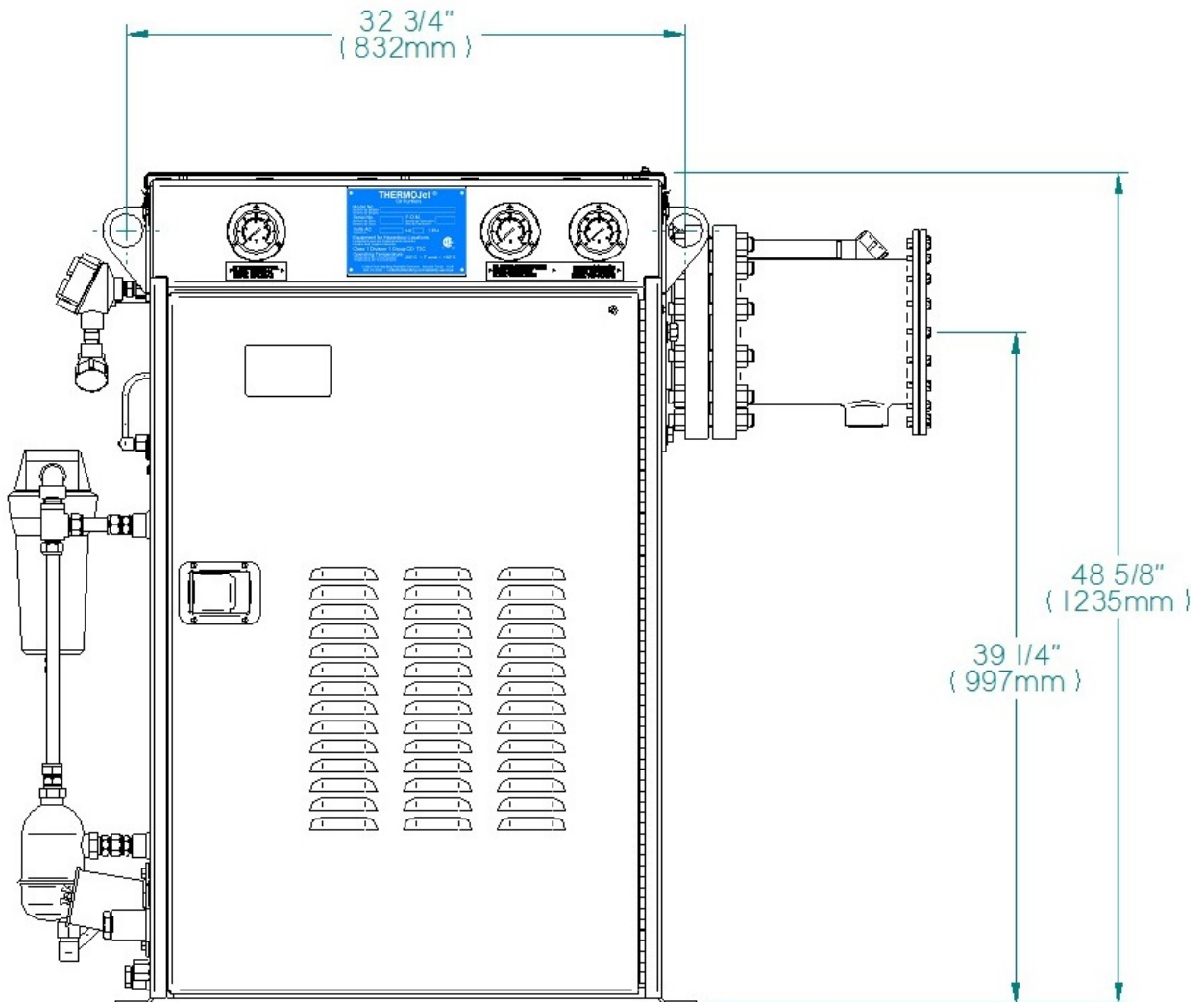

Front View

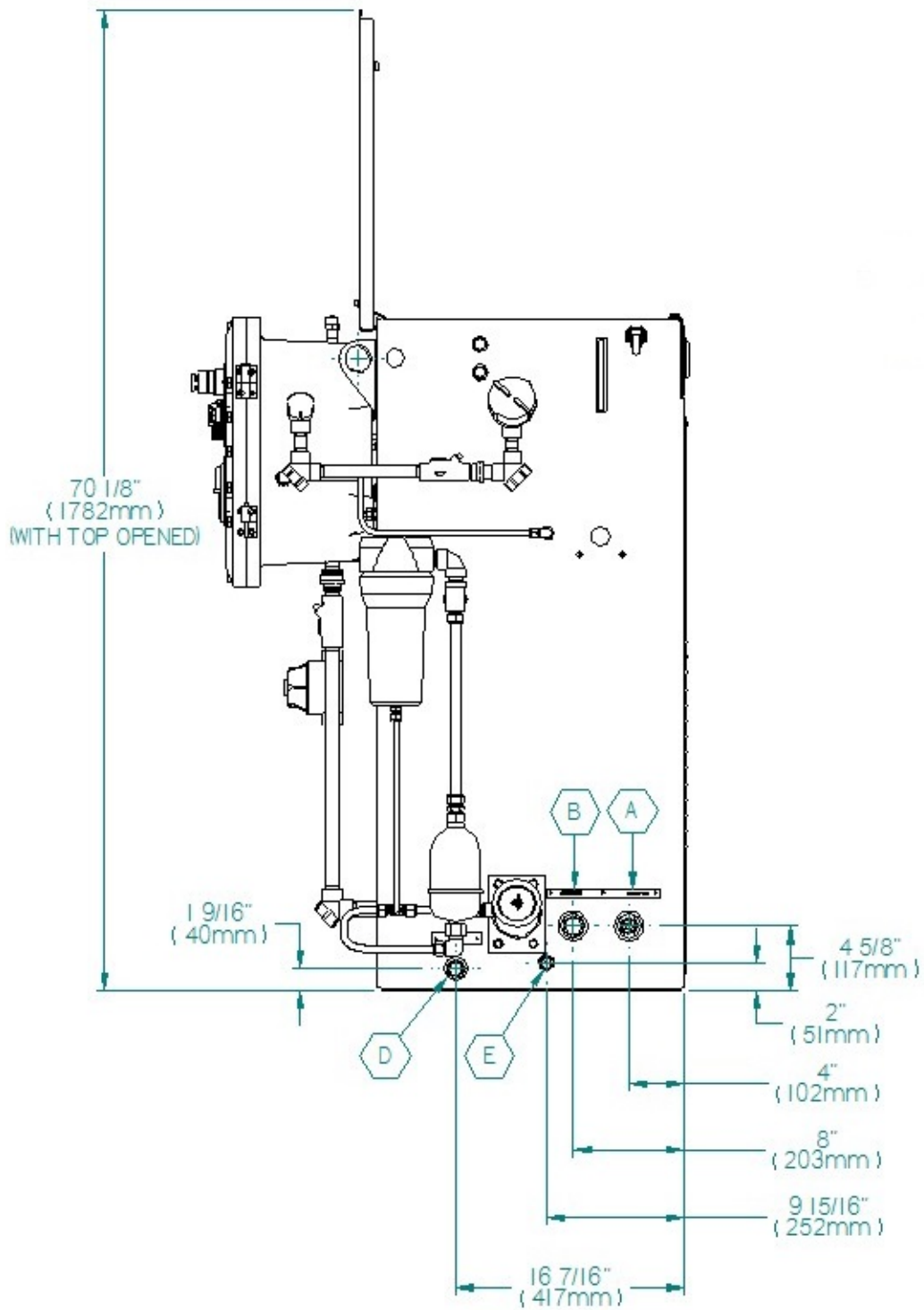

Left Side View

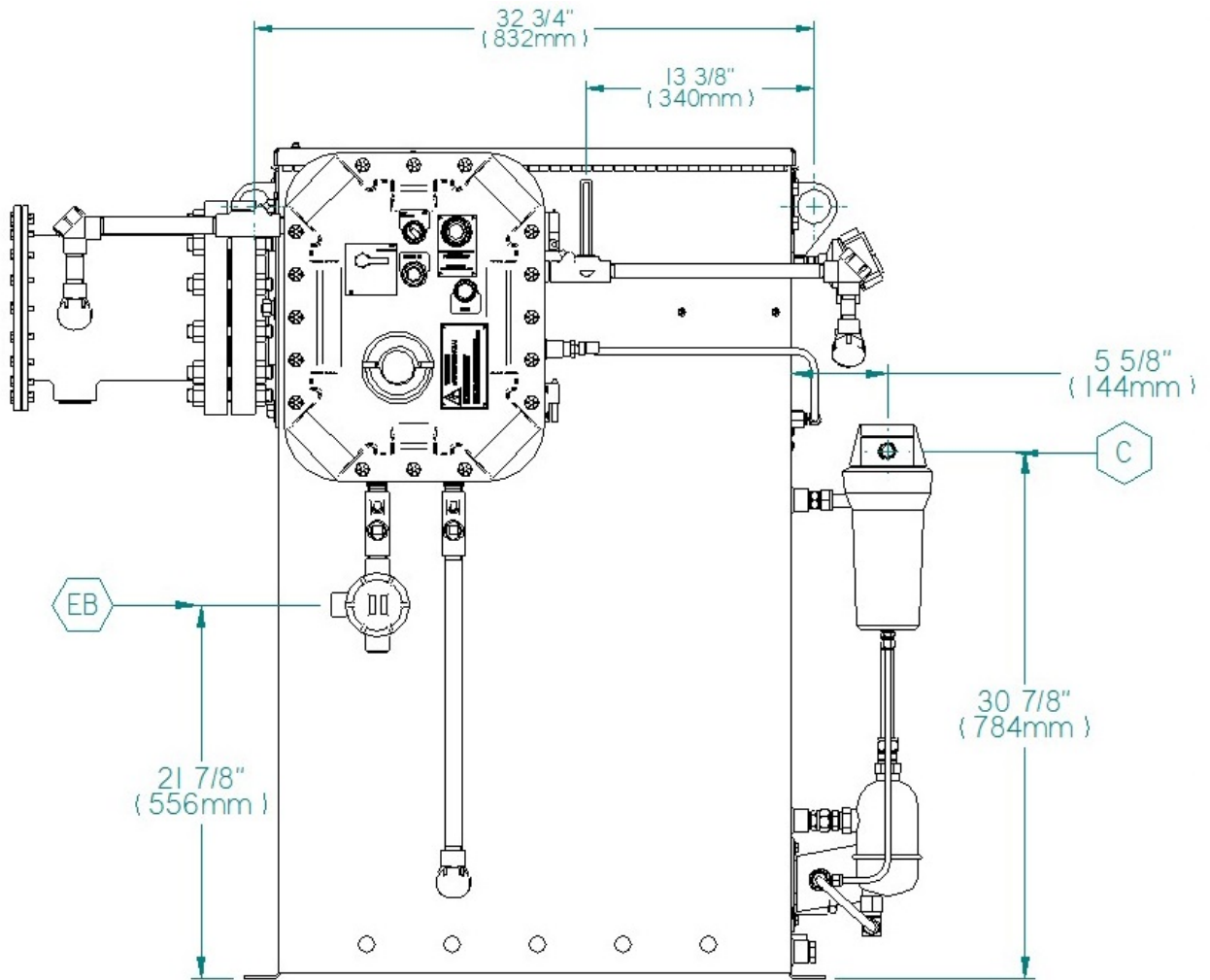

Rear View

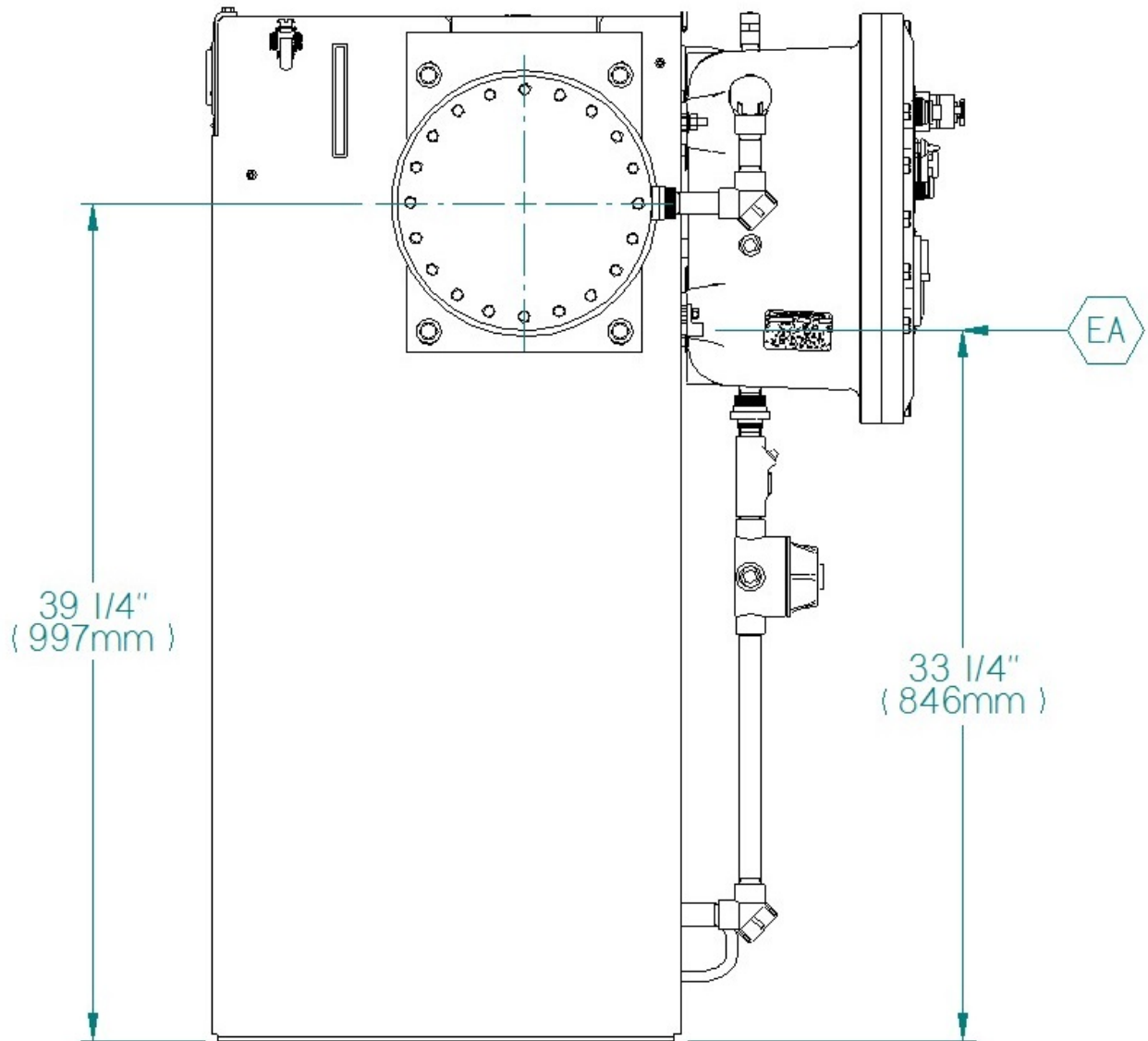

Right Side View

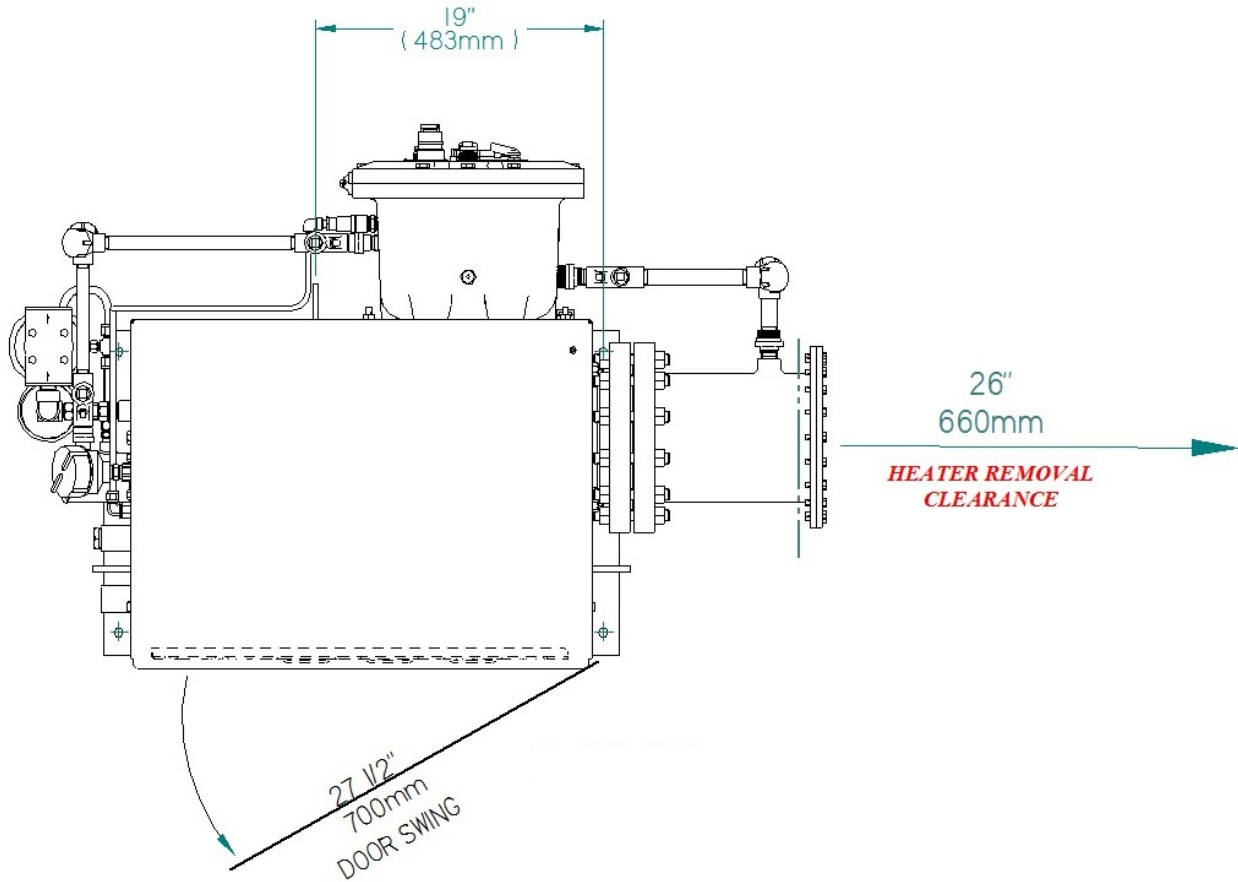

Top View

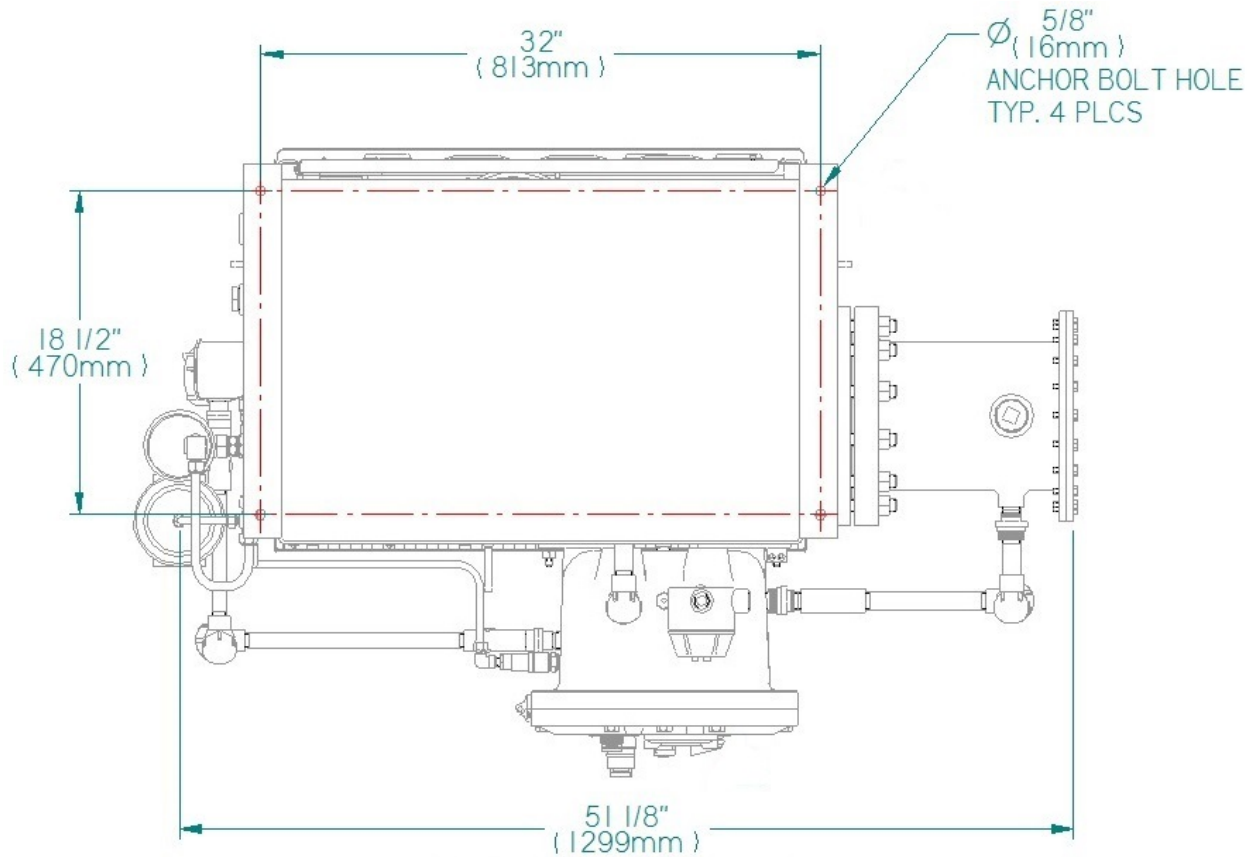

Bottom View
Anchor bolt spacing



**THERMOJET® H-2500E SERIES
OIL PURIFIER SYSTEM
INSTALLATION AND OPERATING MANUAL**

| | |
|-------------------------------|-----------|
| Doc # | 77740119 |
| Rev | 15 |
| Date | June 2020 |
| Page 100 of 100 | |

CUSTOMER CONNECTIONS CHART

| CONN | QTY | DESCRIPTION | TYPE / RATING |
|------|-----|--------------------|----------------------|
| A | 1 | OIL SUPPLY INLET | 1 FNPT |
| B | 1 | OIL RETURN OUTLET | 1" FNPT |
| C | 1 | VENT OUT | 3/4" FNPT |
| D | 1 | PAN DRAIN | 3/4" FNPT, |
| E | 1 | CONDENSATE DRAIN | 1/2" FNPT |
| EA | 1 | GROUNDING LUG | 14-1/0 AWG WIRE SIZE |
| EB | 1 | POWER SUPPLY INLET | 3/4" NPT CONDUIT |